

North-South 400 kV Interconnection Development

An Bord Pleanála Reference: PCI0001

Appendix 7.3

Identification and Resolution of Conflicts with Existing Overhead Line Infrastructure (2015)

(Updated DAF)



DRAFT

TABLE OF CONTENTS

- 1 INTRODUCTION 1**
 - 1.1 PURPOSE OF REPORT 1
- 2 ELECTRICITY TRANSMISSION LINE CROSSINGS 3**
 - 2.1 IDENTIFICATION OF LINE CROSSINGS 3
 - 2.2 MODIFICATIONS AND EVALUATION..... 3
 - 2.2.1 Lisdrum – Louth 110 kV Line (conflict with 400 kV span from Tower 130 to Tower 131)..... 3
 - 2.2.2 Louth – Rathrussan 110 kV Line (conflict with 400 kV span from Tower 180 to Tower 181)..... 6
 - 2.2.3 Arva – Navan 110 kV Line (conflict with 400 kV span from Tower 307 to Tower 308) . 8
- 3 ELECTRICITY DISTRIBUTION OVERHEAD LINES 11**
 - 3.1 IDENTIFICATION OF LINE CROSSINGS AND OUTLINE CONSTRUCTION METHODOLOGY 11
 - 3.2 PROPOSED MODIFICATIONS AND ASSESSMENT 13
 - 3.2.1 Conflict at proposed location of 400 kV Tower No. 114 13
 - 3.2.2 Conflict at proposed location of 400 kV Tower No. 136 15
 - 3.2.3 Conflict at proposed location of 400 kV Tower No. 144 16
 - 3.2.4 Conflict at proposed location of 400 kV Tower No. 169 18
 - 3.2.5 Conflict at proposed location of 400 kV Tower No. 177 19
 - 3.2.6 Conflict at proposed location of 400 kV Tower No. 190 20
 - 3.2.7 Conflict at proposed location of 400 kV Tower No. 195 22
 - 3.2.8 Conflict at proposed location of 400 kV Tower No. 212 23
 - 3.2.9 Conflict at proposed location of 400 kV Tower No. 306 24
 - 3.2.10 Conflict at proposed location of 400 kV Tower No. 313 26
 - 3.2.11 Conflict at proposed location of 400 kV Tower No. 334 27
- 4 OVERHEAD TELECOMMUNICATIONS LINE CROSSINGS 29**
 - 4.1 CONSTRUCTION METHODOLOGY..... 29
 - 4.2 LINE CROSSING LOCATIONS AND EVALUATION..... 30
- 5 CONCLUSIONS 33**

LIST OF FIGURES

Figure 2-1: Example of existing 110 kV poleset being replaced with new and taller poleset (old poles still to be removed) 4

Figure 2-2: Lisdrum – Louth (400 kV span 130 – 131 conflict) 5

Figure 2-3: Louth – Rathrussan (400 kV span 180 – 181 conflict)..... 6

Figure 2-4: Arva – Navan 110 kV (400 kV span 307 – 308 conflict) 9

Figure 3-1: A typical MV line/cable interface pole 12

Figure 3-2: 400 kV Tower 114 conflict..... 14

Figure 3-3: 400 kV Tower 136 conflict..... 15

Figure 3-4: 400 kV Tower 144 conflict..... 17

Figure 3-5: 400 kV Tower 169 conflict..... 18

Figure 3-6: 400 kV Tower 177 conflict..... 19

Figure 3-7: 400 kV Tower 190 conflict..... 21

Figure 3-8: 400 kV Tower 195 conflict..... 22

Figure 3-9: 400 kV Tower 212 conflict..... 23

Figure 3-10: 400 kV Tower 306 conflict..... 25

Figure 3-11: 400 kV Tower 313 conflict..... 26

Figure 3-12: 400 kV Tower 334 conflict..... 28

Figure 4-1: Illustration of Eircom undergrounding practice at a transmission line crossings 29

ANNEXES

- ANNEX A-1: ESBN'S 110 KV LIVE WORKING PROCEDURE (LWP 11008)**
- ANNEX A-2: ESBN'S STANDARD SPECIFICATIONS FOR ESB LV/MV DUCTING**
- ANNEX A-3: ESBN'S STANDARD SPECIFICATIONS FOR ESB 38 KV
DUCTING/CABLING**

DRAFT

1 INTRODUCTION

1.1 PURPOSE OF REPORT

In its role as competent authority under PCI, An Bord Pleanála examined the draft application file under Article 10.4(c) of Regulations 347/2013 and requested that certain specified missing information be submitted. Included in the list of information to be provided is the following request relating to existing overhead lines:

“Confirm where, if any, re-routing of existing overhead lines will be required”.

The purpose of this report is to address the above request, However in addition to identifying those lines which need to be diverted, we have also identified those lines that need to be modified (that is lowered) but not diverted; and furthermore we assess the impact of the associated works.

The report identifies the locations where advance overhead line modification/diversion works will be required at points where the proposed 400 kV line route traverses the following three categories of overhead line infrastructure, namely:

- 1. Electricity Transmission Lines (220 kV, 110 kV);
- 2. Electricity Distribution Lines (38 kV, 20 kV, 10 kV and LV (Low Voltage) lines); and,
- 3. Overhead Telecommunication Lines

The modifications/diversions are required where a conflict has been identified between the existing infrastructure and the proposed development and which conflicts will be resolved by implementing the modifications/diversions in advance of the proposed development. In the case of the electricity transmission and distribution lines the conflicts arise when there is insufficient electrical clearance between the existing lines and the proposed new line or towers at their points of intersection. In the case of overhead telecommunication lines all such lines that are traversed by the proposed development are deemed to be in conflict as it is a requirement of Eircom that all overhead telecommunication lines that are traversed by electricity transmission lines be diverted using underground cable, for a specified distance, either side of the point of intersection with the transmission line.

The proposed specific advance works for each of the three categories of overhead line infrastructure are detailed and an environmental evaluation of the proposed advance works is undertaken. Therefore in the event that approval is granted for the proposed 400 kV line, the re-routing or modifications works will be carried out in advance of the construction of the proposed 400 kV line.

With respect to the first category, modifications to three 110 kV electricity transmission lines are required to ensure that there is sufficient electrical safety clearances between the 110 kV conductor and

the 400 kV conductor at the point of crossing. The modification works are required to lower the height of the three number existing 110 kV electricity transmission lines that are in conflict with the 400 kV electricity transmission line. These modifications will require excavation work, which will be carried out as part of the overall works contract and form part of this proposed development.

As regards the second category, Electricity Distribution Lines conflicts have been identified at the proposed location of eleven 400 kV towers. The conflicts need to be resolved in order to ensure that the 400 kV towers in question can be safely constructed and to ensure that the 400 kV circuit, once energised, maintains adequate electrical safety clearances from the lower line crossing. It is important that the new line can be constructed without any health and safety risks to construction workers involved in the project. It is also important that a safe and secure supply is maintained on both circuits at each conflict site once the proposed 400 kV circuit is energised. These works will be undertaken by ESB Networks in advance of the proposed development and as such do not form part of this proposed development. The proposed works are however assessed and evaluated from an environmental perspective, in the context of the assessment of the project.

As regards the third category of works, the report also identifies and considers the telecommunications crossings along the proposed development. It is a requirement of Eircom that where a proposed overhead transmission line passes over existing overhead telecommunication lines the existing telecommunication line shall be undergrounded in accordance with their specification. The required works will be undertaken by Eircom in advance of the commencement of the proposed development and as such do not form part of this proposed development. The proposed works are however assessed and evaluated from an environmental perspective.

The types and methods of alteration works required to existing lines crossed by the proposed development vary according to the type of utility infrastructure involved and system voltage for electricity line crossings. The locations of the diversions and modifications required for the three overhead line categories, the specific proposed works and the requisite environmental considerations are outlined for each separate line category in the following sections.

2 ELECTRICITY TRANSMISSION LINE CROSSINGS

2.1 IDENTIFICATION OF LINE CROSSINGS

The proposed 400 kV OHL will cross a number of existing 220 kV and 110 kV overhead electricity transmission lines and of these, three 110 kV lines will need to be modified at the following locations.

- Lisdrum – Louth 110 kV Line (conflict with 400 kV span from Tower 130 to Tower 131)
- Louth – Rathrussan 110 kV Line (conflict with 400 kV span from Tower 180 to Tower 181)
- Arva – Navan 110 kV Line (conflict with 400 kV span from Tower 307 to Tower 308)

These three electricity transmission line crossings have been identified as conflicts as there will not be sufficient separation distance between the existing 110 kV electricity wires and the proposed 400 kV wires at the point of crossing under all operating conditions. Modifications to the 110 kV lines are therefore necessary to resolve the conflicts and the required works have been environmentally assessed.

2.2 MODIFICATIONS AND EVALUATION

The advance works proposed at each of the three locations and the associated environmental assessments are outlined in the following sections. These works, which will be undertaken in advance of the proposed development at the relevant locations, will be in accordance with the ESNB's 110 kV Live Working Procedure (LWP 11008), a copy of which is included in Annex A-1 herein.

Where new polesets are required, as with the majority of current electricity and telecommunications infrastructure within Ireland, creosote treated timber poles would be used. The environmental impact arising from creosote from in-service poles is not considered to be significant. Poles are only treated in premises permitted by the EPA in Ireland or by the appropriate regulator for treated poles imported from elsewhere. At manufacturers facilities poles are kept in a negative vacuum for several hours (depending on pole size) following treatment to remove excess creosote. Industry best practice is that all poles are dry before leaving the manufacturers facility.

2.2.1 Lisdrum – Louth 110 kV Line (conflict with 400 kV span from Tower 130 to Tower 131)

Structure alterations will be required on the Lisdrum – Louth 110 kV line, to ensure there are adequate electrical safety clearances maintained between the proposed 400 kV circuit and the existing Lisdrum - Louth 110 kV line under all operating conditions. It is proposed to replace existing 110 kV poleset number 150 with a new wood poleset seven metres lower in height than the existing 21 metre (m) structure. It is also proposed to erect two new polesets in the existing spans either side of the 400 kV crossing to ensure minimum 110 kV ground clearances are maintained. They will be 18 m and 16 m in height respectively.

The new wood poleset structure at position 150 will be erected immediately adjacent to the existing structure (refer Fig 2.1). New excavations of approximately 2.3m depth and approximately 0.5m width will be made at each pole.

Figure 2-1: Example of existing 110 kV poleset being replaced with new and taller poleset (old poles still to be removed)



The excavation for each pole will be carried out using a wheeled or tracked excavator. Each of the two poles are lined up with the excavated holes and the machine operator then drives forward pushing the pole up until the pole is in an almost vertical position. The pole never passes through the point of balance in the vertical position. The pole is supported at all times and the holes manually backfilled to a minimum depth of 1.0m. After excavation and erection of the poleset a further excavation 0.8m deep is necessary. This is a linear excavation perpendicular to the line necessary to install wooden sleepers. These sleepers add additional stability to the poleset and are attached to the poleset using a u-bolt. The two installed poles are connected near the top by a steel crossarm from which three insulators are attached. The conductor is then attached to these insulators during the stringing process. The average duration of poleset installation works is a half a day per poleset with a crew of three personnel.

The location and extent of the proposed works, in the townland of Drumroosk in County Monaghan, is shown on Figure 2-2.

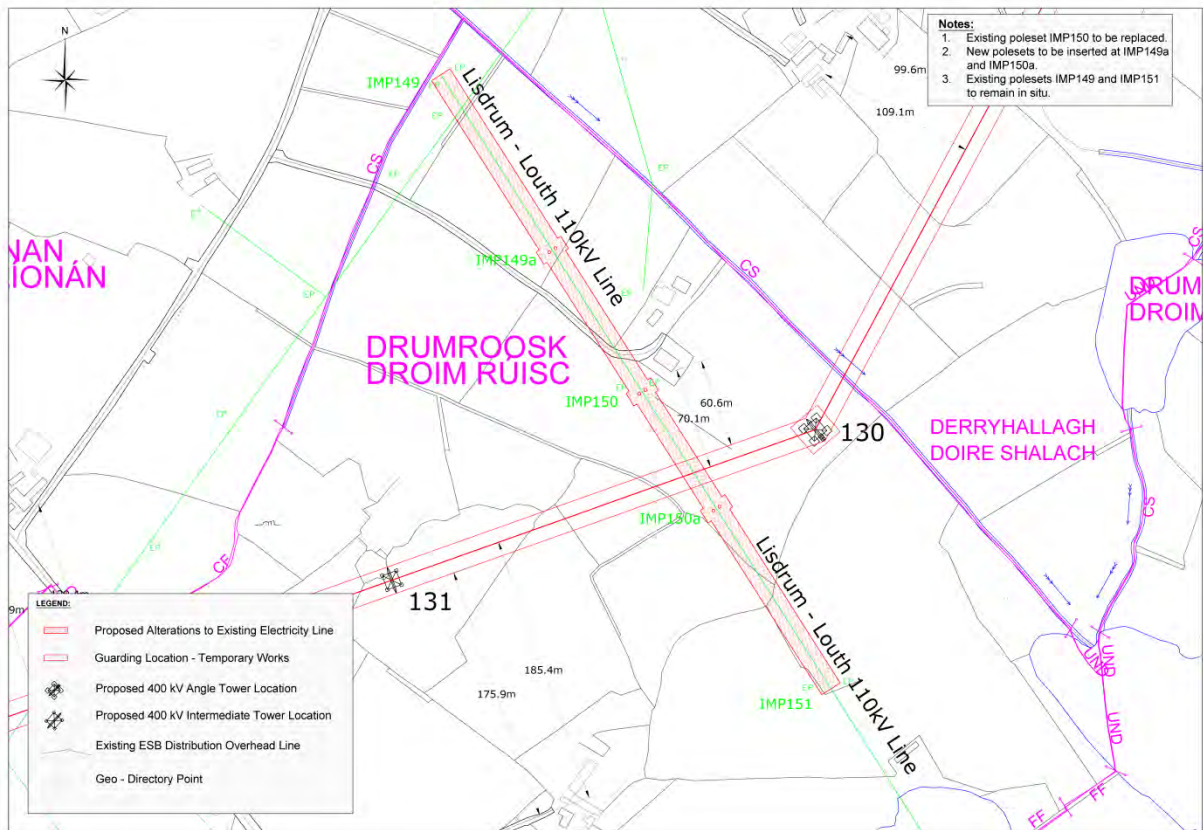
Figure 2-2: Lisdrum – Louth (400 kV span 130 – 131 conflict)

We have carried out an environmental evaluation of the proposed area described above. The area in the immediate vicinity of the proposed crossing point consists of improved grassland of low ecological value. The works area is of low archaeological potential and the works will have no direct impacts on the known cultural heritage resource. The nearest geo-directory point (dwelling) is approximately 70m north of the proposed 400 kV line and approximately 20m north east of the 110 kV pole set No. 150 which will be replaced. The access roads are located approximately 40m north west and 30m west of both polesets.

According to the Monaghan Landscape Character Assessment, the area is located on the edge of two landscape types; these are the 'Drumlin Foothills' and the 'Upland Plateau' and the Landscape Character Area is classified as the 'Monaghan Drumlin Uplands'. The hinterland has poorly drained shallow soils; subsoil classification is a mixture of 'rock close to surface' and 'shale and sandstone till (Lower Palaeozoic)' with no major stream in the vicinity of the proposed crossing point. The visual effects as a result of the modification is believed to be neutral, the overall height of poleset 150 is reduced by 7 m, however there are two addition polesets constructed along the line arrangement.

Given the minor nature and scale of the works proposed as outlined above, which entails replacing an existing poleset with a new and shorter poleset immediately adjacent to the existing poleset and the insertion of two new polesets into the existing span; all of which work will take place within the area

evaluated, which is of low ecological value, with no greater visual impact, nor impact on the landscape character, removed from natural surface waters and known sites or monuments, there will be no significant impacts on the receiving environment.

2.2.2 Louth – Rathrussan 110 kV Line (conflict with 400 kV span from Tower 180 to Tower 181)

Structure alterations will be required on the Louth – Rathrussan 110 kV line, to ensure there are adequate electrical safety clearances maintained between the proposed 400 kV circuit and the existing Louth – Rathrussan 110 kV line. The location and extent of the proposed works, in the townland of Corrinenty in County Monaghan, is shown on Figure 2-3.

It is proposed to replace existing 110 kV poleset number 100 with a new wood poleset one metre lower in height than the existing 21m structure. It is also proposed to replace existing intermediate tower number 101 with a new wood poleset one metre lower in height than the existing 21m structure.

Figure 2-3: Louth – Rathrussan (400 kV span 180 – 181 conflict)

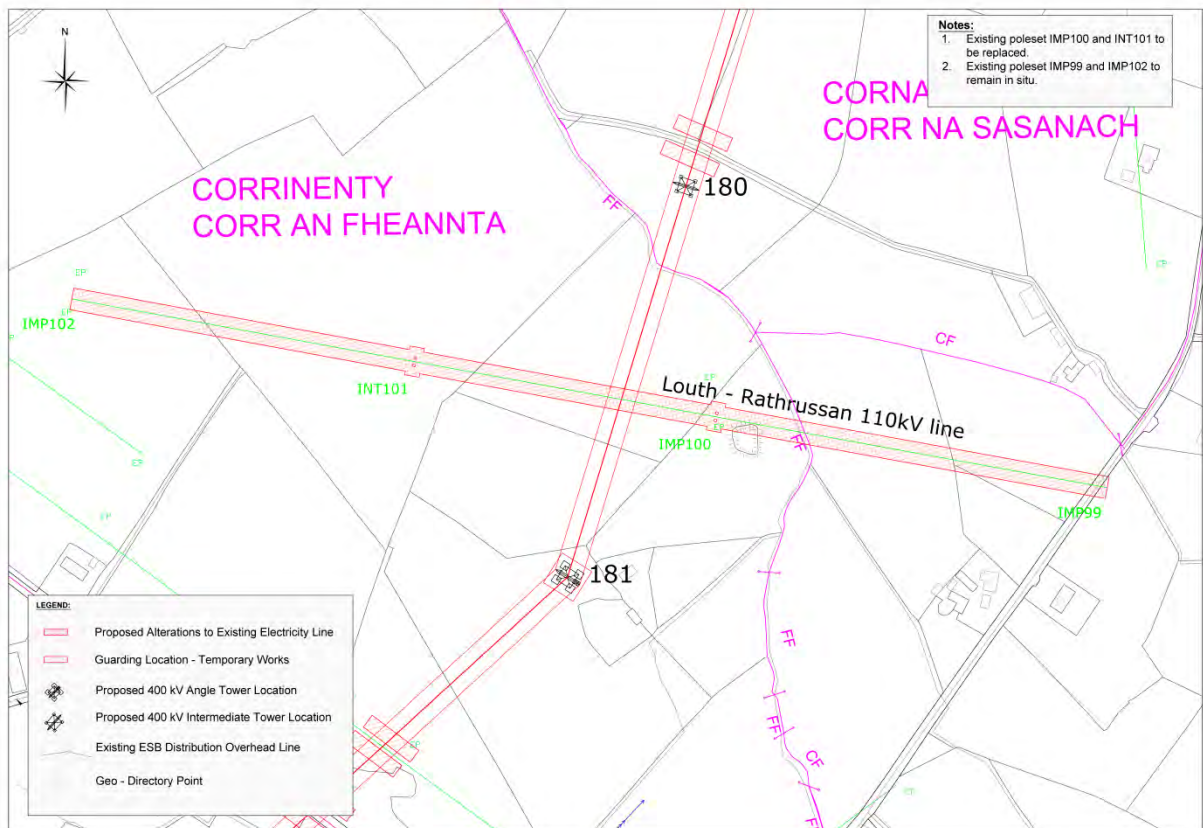

At poleset No. 100, the new poleset will be placed in an excavation immediately adjacent to the butt of the old wood poles. When the new poleset is erected, the existing structure will then be retired. At intermediate Tower No. 101, the existing steel structure will be retired. The new wood poleset at position 101 will be erected at the same location as the old intermediate tower. An excavation 2.3m

deep and approximately 0.5m wide will be made at each pole. The excavation for each pole will be carried out using a wheeled or tracked excavator. Each of the two poles are lined up with the excavated holes and the machine operator then drives forward pushing the pole up until the pole is in an almost vertical position. The pole never passes through the point of balance in the vertical position. The pole is supported at all times and the holes manually backfilled to a minimum depth of 1.0m. After excavation and erection of the poleset a further excavation 0.8m deep is necessary. This is a linear excavation perpendicular to the line necessary to install wooden sleepers. These sleepers add additional stability to the poleset and are attached to the poleset using a u-bolt. The two installed poles are connected near the top by a steel crossarm from which three insulators are attached. The conductor is then attached to these insulators during the stringing process. The average duration of poleset installation works is a half a day per poleset with a crew of three personnel.

We have carried out an environmental evaluation of the works required to resolve the conflict between the proposed 400 kV overhead line and the existing 110 kV overhead line.

The area in the immediate vicinity of the proposed crossing point consists of semi improved grassland of low ecological value. The area under the proposed line consists of dense vegetation. The works area is of low archaeological potential and the works will have no direct impacts on the known cultural heritage resource, however it is noted that a record enclosure is located approximately 100m east of the proposed 400 kV line. This enclosure is oversailed by the existing 110 kV line. The nearest poleset to be replaced is located <20m to the west of the enclosure. There is potential that works here may inadvertently impact on sub surface archaeological remains associated with the enclosure. It is therefore recommended that a suitably qualified archaeologist monitor all groundworks associated with removing the polesets to facilitate reducing the height of the existing 110 kV line. The enclosure will be clearly demarcated and its location highlighted to the construction contractor. The nearest geo-directory point (dwelling) is approximately 250m east of the line. The nearest local roads are located approximately 250m east and 325m south west of the proposed tower location. .

According to the Monaghan Landscape Character Assessment, the area is located on the edge of the Landscape Character Type 'Farmed Foothills' and the Landscape Character Area 'Drumlin and Upland Farmland of South Monaghan'. The polesets are located approximately 2.7km away from VP 22 as defined in Monaghan County Development Plan 2007-2013. The hinterland has poorly drained shallow soils; subsoil classification a mixture of 'rock close to surface' and 'shale and sandstone till (Lower Palaeozoic)' with no major stream in the vicinity of the proposed crossing point. As the works will involve replacing the existing polesets with new poles which are lower in height at the same location, there will be no impact on landscape or views

Given the minor nature and scale of the works proposed works as outlined above, which entails replacing existing structures with new and shorter polesets immediately adjacent to the existing structures within the area evaluated, which is of low ecological value, with no greater visual impact, nor

impact on the landscape character, removed from natural surface waters, there will be no significant impacts on the receiving environment once the specific mitigation measures in relation to the enclosure as outlined above are implemented.

2.2.3 Arva – Navan 110 kV Line (conflict with 400 kV span from Tower 307 to Tower 308)

Structure alterations will be required on the Arva - Navan 110 kV line, to ensure there are adequate electrical safety clearances maintained between the proposed 400 kV circuit and the existing Arva – Navan 110 kV line. It is proposed to replace existing 110 kV poleset No. 314 with a new poleset one metre lower in height than the existing 17 m structure. It is also proposed to replace existing 110 kV poleset No. 315 with a new poleset two metres lower in height than the existing 18 m structure.

Therefore the two new poleset will be erected immediately adjacent to the existing structures. Both new structures will be placed in an excavation immediately adjacent to the butt of the old wood poles. When the new poleset is erected, the existing structure will then be retired. An excavation approximately 2.3m deep and approximately 0.5 m wide will be made at each pole. The excavation for each pole will be carried out using a wheeled or tracked excavator. Each of the two poles are lined up with the excavated holes and the machine operator then drives forward pushing the pole up until the pole is in an almost vertical position. The pole never passes through the point of balance in the vertical position. The pole is supported at all times and the holes manually backfilled to a minimum depth of 1.0m. After excavation and erection of the poleset a further excavation 0.8m deep is necessary. This is a linear excavation perpendicular to the line necessary to install wooden sleepers. These sleepers add additional stability to the poleset and are attached to the poleset using a u-bolt. The two installed poles are connected near the top by a steel crossarm from which three insulators are attached. The conductor is then attached to these insulators during the stringing process. The average duration of poleset installation works is a half a day per poleset with a crew of three.

The location and extent of the proposed works, in the townlands of Teltown and Gibstown Demesne in County Meath, is shown on Figure 2-4.

Figure 2-4: Arva – Navan 110 kV (400 kV span 307 – 308 conflict)

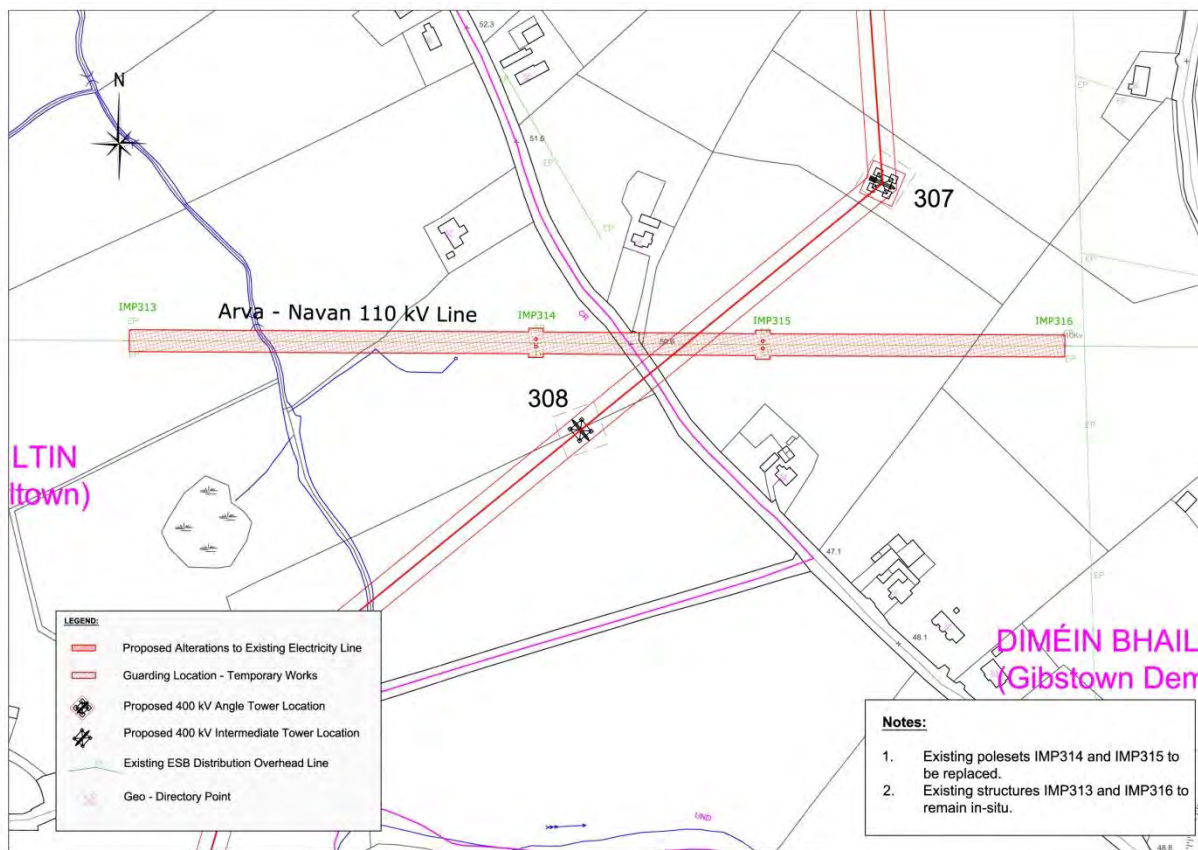

We have carried out an environmental evaluation of the proposed works to resolve the conflict between the proposed 400 kV overhead line and the existing 110 kV overhead line.

The area in the immediate vicinity of the proposed crossing point consists of improved grassland of low ecological value. The works area is of low archaeological potential and there will be no direct impacts on the known cultural heritage resource, however it is noted that some of the works are situated within Gibstown Demesne. The polesets are located over 1km from the site of Gibstown house. The nearest geo-directory point (dwelling) is approximately 70m north west of the proposed 400 kV line and approximately 70m north of the existing 110 kV line. The proposed works on the 110 kV line cross an existing road. The works will have no effect on traffic flow along this road as all that will be altered at the road crossing is the height of the conductors above the road and this height will remain sufficiently high, even during the course of the works, to permit traffic to flow.

According to the Meath Landscape Character Assessment, the underground cable area is located in the 'Blackwater Valley Landscape Character Area' within the 'River Corridors and Estuaries Landscape Character Type'. This Landscape Character Area had been classified as Very High Landscape Value, Regional Importance and High Sensitivity. The area is located approximately 10km away from the 'Tower at Kells' - Protected View of National Significance and approx. 2.5km away from Protected View 80, as indicated in the Meath County Development Plan 2013 - 2019. As the works will involve replacing

the existing polesets with new poles which are lower in height at the same location, there will be no impact on landscape or views. The hinterland has dry deep acidic soils; subsoil classification 'shale and sandstone till (Lower Palaeozoic)' with no major stream in the vicinity of the proposed crossing point.

Given the minor nature and scale of the works proposed as outlined above, which entails replacing existing polesets with new and shorter polesets immediately adjacent to the existing polesets within the area evaluated, which is of low ecological value, with no greater visual impact, nor impact on the landscape character, removed from natural surface waters and known sites or monuments, there will be no significant impacts on the receiving environment.

DRAFT

3 ELECTRICITY DISTRIBUTION OVERHEAD LINES

3.1 IDENTIFICATION OF LINE CROSSINGS AND OUTLINE CONSTRUCTION METHODOLOGY

The electricity distribution line overhead crossings where there is a conflict between a 400 kV structure and a lower voltage crossing have been identified and the proposed modification to resolve the conflict has been environmentally assessed.

Existing medium and lower voltage overhead lines that cross the route of the proposed overhead line have been assessed to calculate the dimensional clearance between these existing lines and the position of the proposed 400 kV conductors associated with the proposed overhead line. In circumstances where this clearance has been deemed sufficient to permit both overhead lines to operate safely together then these lines will be guarded during construction, and if deemed necessary, switched off during construction and then re-energised afterwards. Where a conflict is identified it will be resolved by undergrounding the distribution line. Conflicts have been identified where existing distribution lines pass through, or too close to, the proposed location of eleven 400 kV towers.

The construction methodology which will be employed for the proposed existing overhead line diversions will entail the placement of an underground cable in place of the existing overhead line, with the existing poles and overhead electricity wires over the requisite length being removed. New line/cable interface poles (see example of an MV line/cable interface pole in Figure 3-1) will also be necessary to join the underground cable with the existing overhead line. These works, which will be undertaken in advance of the proposed development, will be in accordance with the ESBN's Standard Specifications for ESB LV/MV Ducting and ESBN's Standard Specifications for ESB 38 kV Ducting/Cabling. Copies of both these standard specifications are included in Annex A. The location of the line/cable interface structures and route of the UGC from one structure to the other will be determined by ESBN in consultation with the owner of the landholdings concerned.

Figure 3-1: A typical MV line/cable interface pole

The start and end points of the underground cable route will be a minimum distance of 10m from the outer phase either side of the proposed 400 kV line. This is the minimum distance that ESB Networks require any new lower voltage structure to be from the proposed 400 kV circuit. For example, on the proposed 400 kV single circuit section, the underground cable route would extend to a minimum of 19.5m either side of the 400 kV route resulting in a minimum overall distance of 39 m. For the purposes of the environmental evaluation, for all 38 kV lines a cable trench of 600mm width and 1,220mm depth, similar to that shown in Figure 1A of Annex A-3 is considered. A woodpole structure, similar to that shown in Figure 3B of Annex A-3 will be constructed at both ends of the 38 kV underground cable route.

For all 20 kV, 10 kV and LV lines a cable trench of 360mm width and a maximum of 1,000mm depth is considered and it is assumed that a single wood pole structure with two stays will be constructed at both ends of the 20 kV, 10 kV or LV underground cable route.

Where new polesets are required, as with the majority of current electricity distribution infrastructure within Ireland, creosote treated timber poles would be used. The environmental impact arising from creosote from in-service poles is not considered to be significant. Poles are only treated in premises permitted by the EPA in Ireland or by the appropriate regulator for treated poles imported from elsewhere. At manufacturers facilities poles are kept in a negative vacuum for several hours (depending on pole size) following treatment to remove excess creosote. Industry best practice is that all poles are dry before leaving the manufacturers facility.

The excavation for each line/cable interface pole will be carried out using a wheeled or tracked excavator. Each line/cable interface pole are lined up with the excavated holes and the machine operator then drives forward pushing the pole up until the pole is in an almost vertical position. The pole never passes through the point of balance in the vertical position. The pole is supported at all times and the holes manually backfilled to a minimum depth of 1m. The line/cable interface poles installed with a steel crossarm from which the insulators are attached. The conductor and cables are then attached to these insulators during the stringing process.

In order to minimise the construction impacts, thrust boring will be used under any significant watercourses. This process will not involve an open trench as it will be done by micro-tunnelling and so will avoid any likely significant effects.

3.2 PROPOSED MODIFICATIONS AND ASSESSMENT

The advance works proposed at each of the eleven locations and the associated environmental assessments are outlined in the following sections.

3.2.1 Conflict at proposed location of 400 kV Tower No. 114

An environmental assessment and an evaluation has been carried out on an area around Tower 114 in which an underground cable will be routed to resolve the conflict between the proposed location of Tower 114 and the existing overhead line supplying a building located to the north of the proposed 400 kV line. The area evaluated is detailed on Figure 3-2 below. This area is situated in the townland of Latnakelly, Co. Monaghan. The underground cable route starts at a line/cable interface structure position south of Tower 114 and will be routed either east or west of the proposed 400 kV structure to line/cable interface structure north of the proposed 400 kV structure.

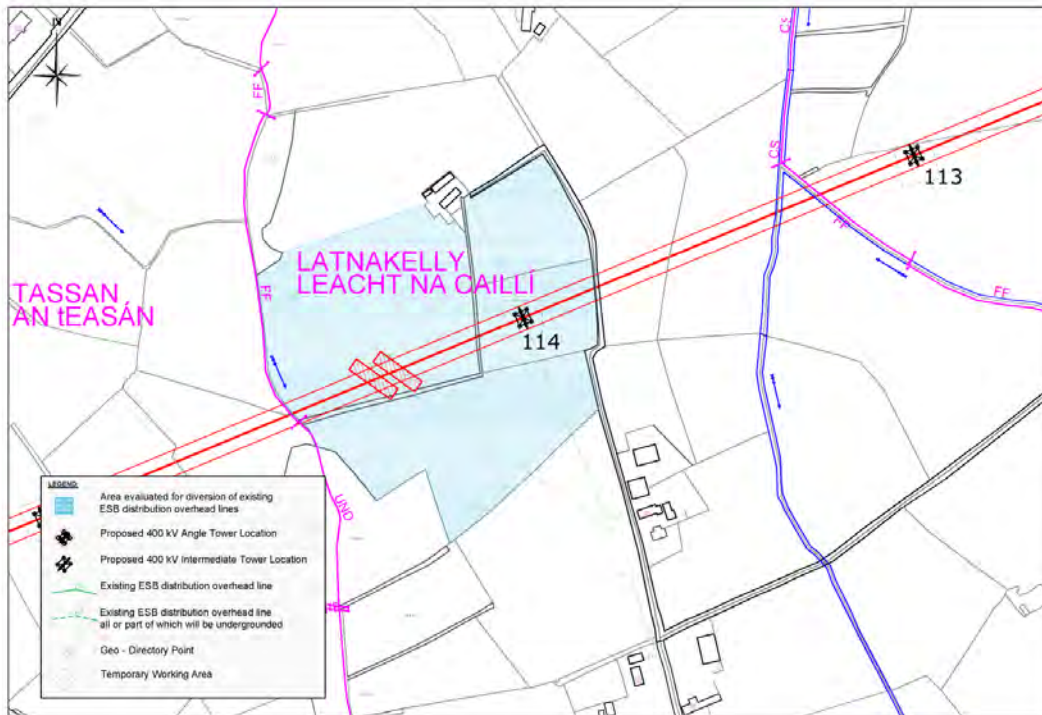
Figure 3-2: 400 kV Tower 114 conflict

The area in the immediate vicinity of Tower 114 consists of improved grassland of low ecological value. The cable routes will start to the south of Tower 114 and will pass through a maximum of two hedgerows.

The underground zone is located on a lower slope of a drumlin with the nearest local road approximately 250m south from the proposed structure location. Views of the line/cable interface structures from the local road to the south will have no greater visual impact than a standard single pole.

According to the Monaghan Landscape Character Assessment, the route is located within the Landscape Character Type 'Upland Plateau' and within the Landscape Character Area 'Mullyash Uplands'. There are no major streams or known sites or monuments recorded in the vicinity of the route. A desk survey showed the ground conditions as poorly drained soils - subsoil classification - Shale and Sandstone Till (Lower Palaeozoic). The hinterland around Tower 114 consists of no key constraints or ancillary works with the nearest geo-directory point (dwelling) approximately 155m south east of Tower 114.

Given the minor nature and scale of the works proposed within the area evaluated, which is improved grassland of low ecological value, with no greater visual impact, nor impact on the landscape character and removed from natural surface waters and known sites or monuments, there will be no significant impacts on the receiving environment.

3.2.2 Conflict at proposed location of 400 kV Tower No. 136

An environmental assessment and an evaluation has been carried out on an area around Tower 136 in which an underground cable will be routed to resolve the conflict between the proposed location of Tower 136 and the existing 10 kV overhead line. The area evaluated is detailed on Figure 3-3 below. This area is situated in the townland of Cornanure, Co. Monaghan. The underground cable route will start at a line/cable interface structure position to the west of Tower 136 and will be routed either north or south of the proposed structure location to connect to a line/cable interface structure east of the proposed 400 kV structure.

Figure 3-3: 400 kV Tower 136 conflict

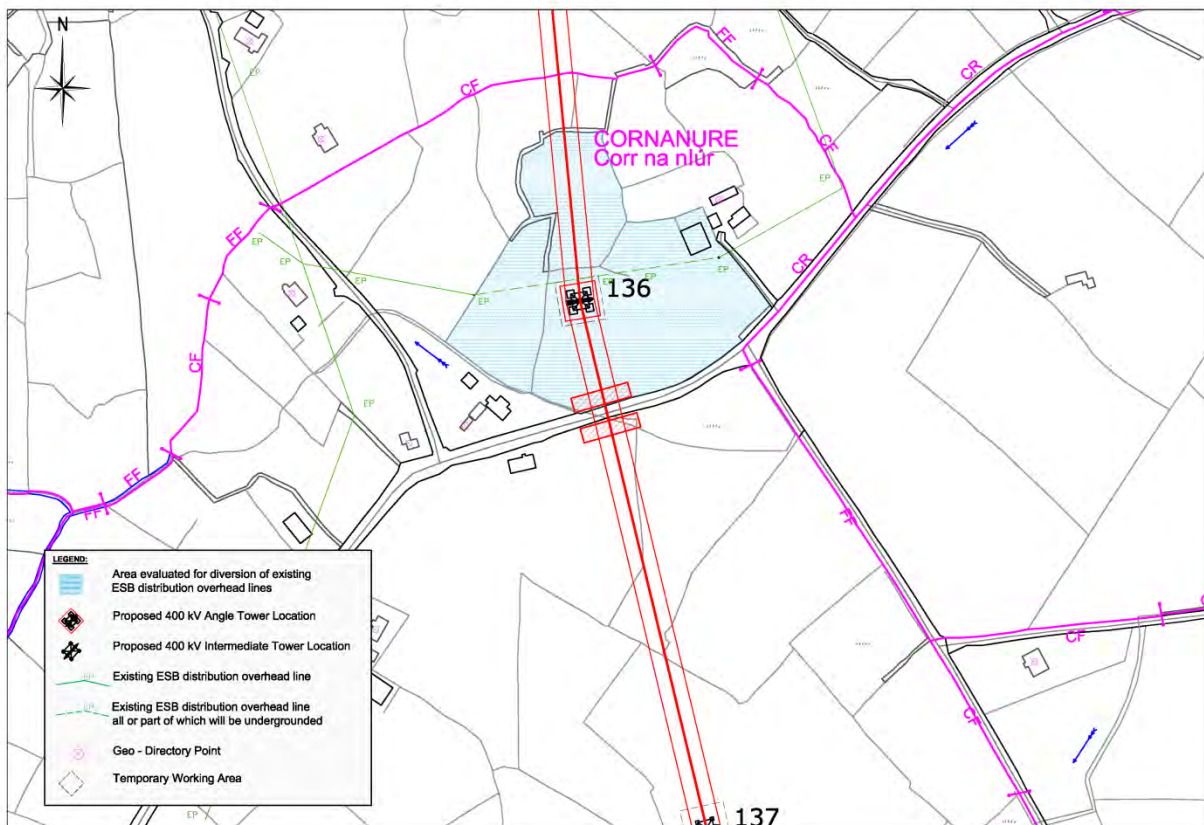

The area in the immediate vicinity of Tower 136 consists of semi-improved grassland of low ecological value. The route will start to the west of Tower 136 and pass to the east with a route passing through a maximum of two hedgerows.

The two closest geo-directory points (dwellings) are approximately 100m south west and 100m north east of Tower 136. The cable zone is of low archaeological potential and there will be no direct impacts on the known cultural heritage resource.

The existing 10 kV line east to west with the line approximately 75m north of a local road and approximately 60m east of another local road within a network of fields and hedgerows with small trees. Views of the line/cable interface structures from the local road network will have no greater visual impact than the current standard single pole.

According to the Monaghan Landscape Character Assessment, the area is located within the Landscape Character Type 'Drumlin Foothills' and within the Landscape Character Area 'Monaghan Drumlin Uplands'. The hinterland has poorly drained shallow soils; subsoil classification - rock close to surface. There are no major streams in the vicinity of the underground route.

Given the minor nature and scale of the works proposed within the area evaluated, which is semi-improved grassland of low ecological value, with no greater visual impact, nor impact on the landscape character and removed from natural surface waters and known sites or monuments, there will be no significant impacts on the receiving environment.

3.2.3 Conflict at proposed location of 400 kV Tower No. 144

An environmental assessment and an evaluation has been carried out on an area around Tower 144 in which an underground cable will be routed to resolve the conflict between the proposed location of Tower 144 and the existing 38 kV overhead line. The area evaluated is detailed on Figure 3-4 below. This area is situated in the townland of Cornamucklagh South, Co. Monaghan. The underground cable route starts at a line/cable interface structure position south west of Tower 144 and will be routed either north or south of the proposed 400 kV structure to a line/cable interface structure east of the proposed 400 kV structure.

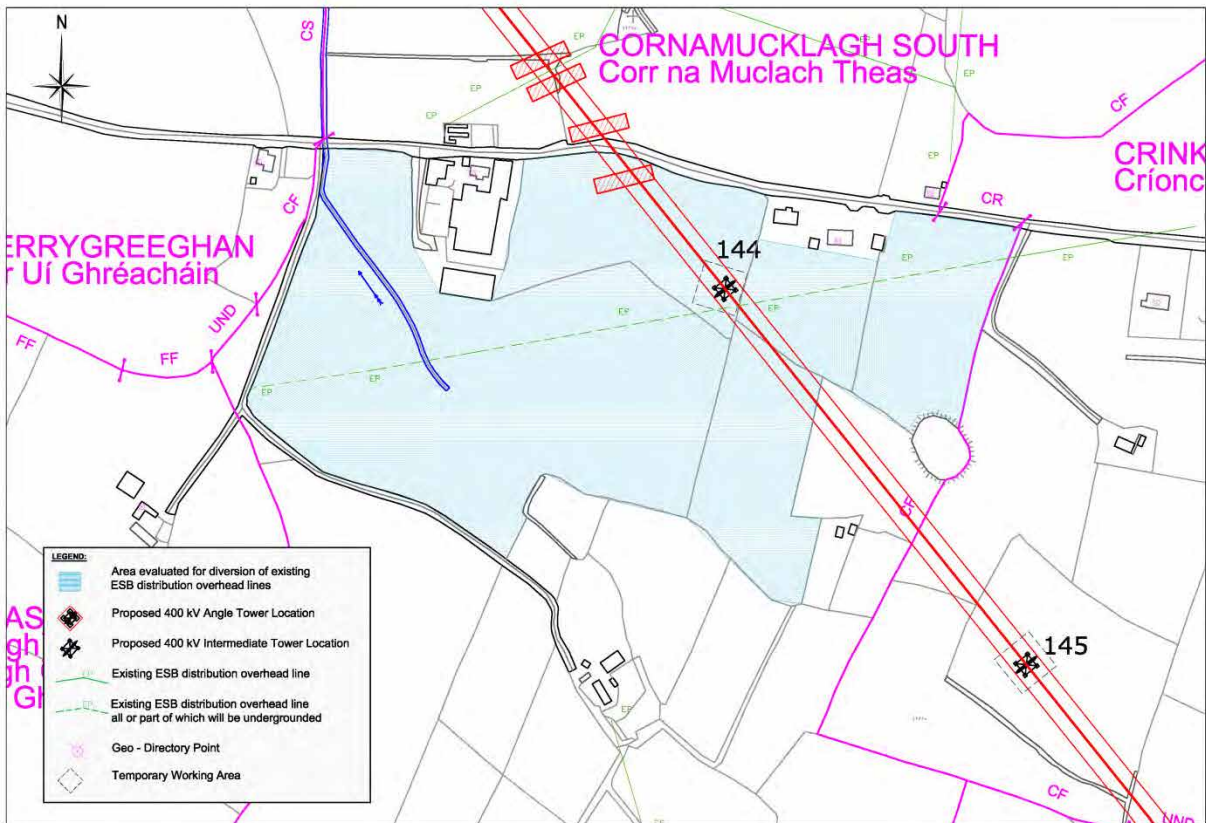
Figure 3-4: 400 kV Tower 144 conflict

The area in the immediate vicinity of Tower 144 consists of improved grassland of low ecological value. The tower is located in close proximity to managed hedgerows in the south west corner of the field. The cable route will pass through a minimum of two hedgerows.

The area is located on a lower slope of a drumlin with the nearest local road approx. 400m west from the proposed tower location. Other roads in vicinity are a local road approx. 400m to the south of the proposed tower and local access lane approx. 150m to the north east. Views of the line/cable interface structures from the local road network will have no greater visual impact than the current standard single pole.

The two closest geo-directory points (dwellings) are approximately 73m and 145m to the north east of Tower 144. The area is of low archaeological potential and there will be no direct impacts on the known cultural heritage resource, with the nearest known site or monument recorded within 135m, south east of Tower 144.

Given the minor nature and scale of the works proposed within the area evaluated, which is improved grassland of low ecological value, with no greater visual impact, nor impact on the landscape character and removed from natural surface waters and known sites or monuments, there will be no significant impacts on the receiving environment.

3.2.4 Conflict at proposed location of 400 kV Tower No. 169

An environmental assessment and an evaluation has been carried out on an area around Tower 169 in which underground cables will be routed to resolve the conflict between the proposed location of Tower 169 and the three existing overhead lines. The area evaluated is detailed on Figure 3-5 below. This area is situated in the townland of Drumillard, Co. Monaghan. Three separate underground cable routes will be required commencing and terminating at line/cable interface structures, routed either north or south of the proposed 400 kV structure (Tower 169). These will pass through at least one hedgerow and possibly two hedgerows.

Figure 3-5: 400 kV Tower 169 conflict

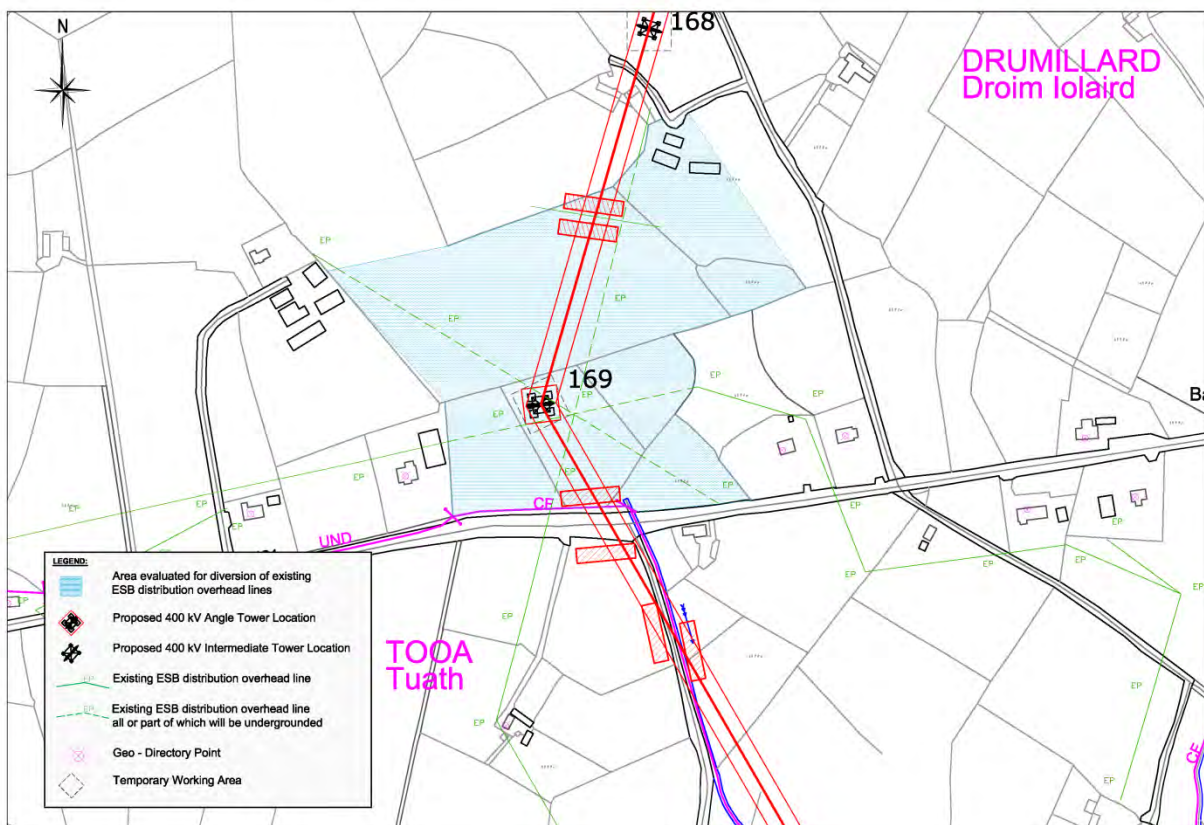

The area in the immediate vicinity of Tower 169 consists of semi-improved grassland and wet grassland of low ecological value. The three underground cable routes travel a short distance however all three pass through a single hedgerow to the North and West of Tower 169 respectively.

The two closest geo-directory points (dwellings) are approximately 95m west and 125m east of Tower 169. The cable routes are located in a field, on the lower slope of a drumlin, located close to a road; R181 is located approx. 75m south of Tower 169. There is a local road located approx. 600m west and a scenic route located approx. 900m south west from Tower 169. Views of the line/cable interface

structures from the local road network will have no greater visual impact than the current standard single pole. There will be no views from the scenic route due to topography and existing vegetation.

According to the Monaghan Landscape Character Assessment, the underground cable zone is located within the Landscape Character Type 'Drumlin Foothills' and within the Landscape Character Area 'Drumlin and Upland Farmland of South Monaghan'. The cable zone is located approximately 0.8km away from VP 22 as defined in Monaghan County Development Plan 2007-2013. The area assessed is of low archaeological potential and there will be no direct impacts on the known cultural heritage resource. The hinterland has poorly drained soils; subsoil classification - shale and sandstone till (Lower Palaeozoic). There are no major streams in the vicinity of the underground zone.

Given the minor nature and scale of the works proposed within the area evaluated, which is semi-improved grassland and wet grassland of low ecological value, with no greater visual impact, nor impact on the landscape character and removed from natural surface waters and known sites or monuments, there will be no significant impacts on the receiving environment.

3.2.5 Conflict at proposed location of 400 kV Tower No. 177

An environmental assessment and an evaluation has been carried out on an area around Tower 177 in which an underground cable will be routed to resolve the conflict between the proposed location of Tower 177 and the existing LV overhead line. The area evaluated is detailed on Figure 3-6 below.

Figure 3-6: 400 kV Tower 177 conflict

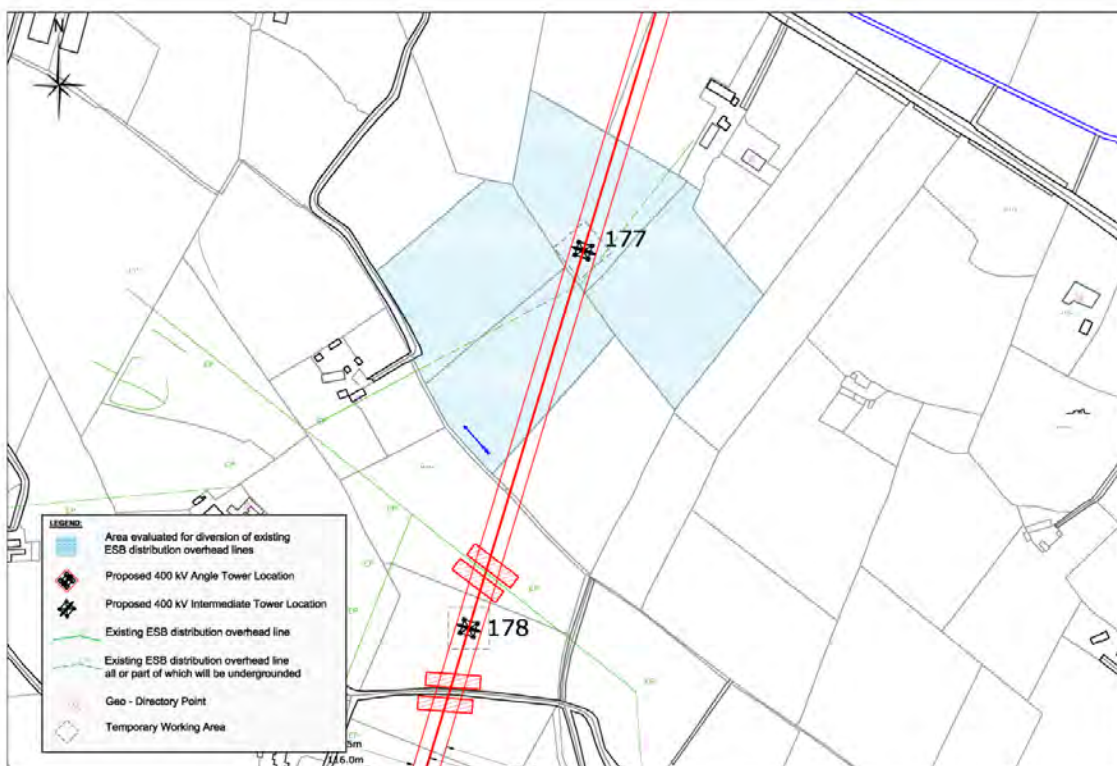

This area is situated in the townland of Cornasassonagh, Co. Monaghan. The underground cable route starts at a line/cable interface structure position south west of Tower 177 and will be routed to a line/cable interface structure north east of the proposed 400 kV structure.

The area in the immediate vicinity of Tower 177 consists of improved grassland of low ecological value. The route connecting the two line/cable interface structures will likely pass through a maximum of two hedgerows. There are two geo-directory points (dwellings) approximately 185m and 125m from Tower 177 (approximately 91m and 121m from the line). Views of the line/cable interface structures from the local road network will have no greater visual impact than the current standard single pole.

The underground cable zone is of low archaeological potential and there will be no direct impacts on the known cultural heritage resource. A desk survey showed the ground conditions as poorly drained soils - subsoil classification - Shale and Sandstone Till (Lower Palaeozoic).

According to the Monaghan Landscape Character Assessment, the underground zone is located within the Landscape Character Type 'Farmed Foothills' and within the Landscape Character Area 'Drumlin and Upland Farmland of South Monaghan'. The 400 kV tower is located approximately 2.2km away from VP 22 as defined in Monaghan County Development Plan 2007-2013.

Given the minor nature and scale of the works proposed within the area evaluated, which is improved grassland of low ecological value, with no greater visual impact, nor impact on the landscape character and removed from natural surface waters and known sites or monuments, there will be no significant impacts on the receiving environment.

3.2.6 Conflict at proposed location of 400 kV Tower No. 190

An environmental assessment and an evaluation has been carried out on an area around Tower 190 in which an underground cable will be routed to resolve the conflict between the proposed location of Tower 190 and the existing 10 kV overhead line. The area evaluated is detailed on Figure 3-7 below. This area is situated in the townland of Ardragh, Co. Monaghan. The underground cable route starts at a line/cable interface structure position south west of Tower 190 and will be routed to a line/cable interface structure north east of the proposed 400 kV structure.

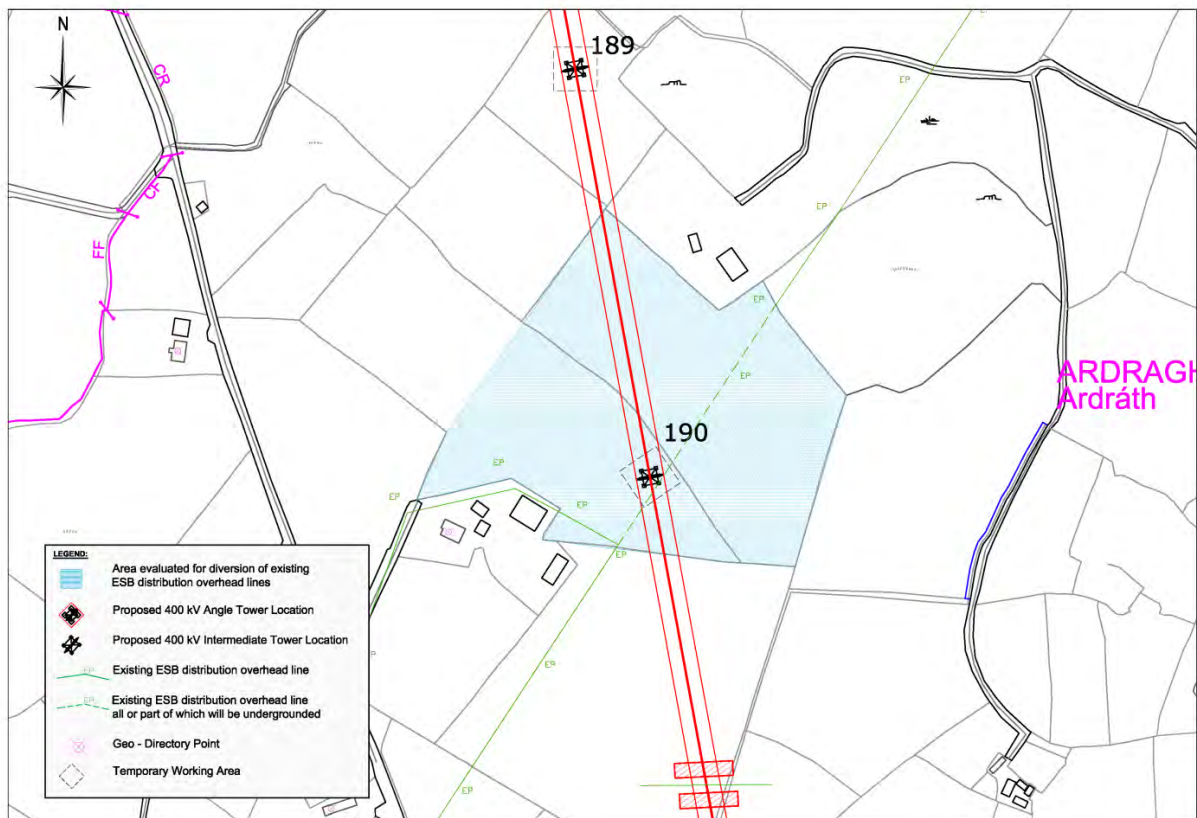
Figure 3-7: 400 kV Tower 190 conflict

The area in the immediate vicinity of Tower 190 consists of improved grassland of low ecological value. The route will start to the north west and finish to the south west of Tower 190, the route will pass through a maximum of two hedgerows.

There is a geo-directory point (dwelling) approximately 130m to the south west, with no known key constraints or ancillary works in close proximity. There is a 'rock' noted on the 1st edition map approximately 100m to the west. The tower location is of low archaeological potential and there will be no direct impacts on the known cultural heritage resource. Views of the line/cable interface structures from the local road network will have no greater visual impact than the current standard single pole.

The hinterland has poorly drained shallow soils; subsoil classification - rock close to surface. No major stream in the vicinity of the underground route. According to the Monaghan Landscape Character Assessment, the route is located within the Landscape Character Type 'Farmed Foothills' and within the Landscape Character Area 'Drumlin and Upland Farmland of South Monaghan'.

Given the minor nature and scale of the works proposed within the area evaluated, which is improved grassland of low ecological value, with no greater visual impact, nor impact on the landscape character and removed from natural surface waters and known sites or monuments, there will be no significant impacts on the receiving environment.

3.2.7 Conflict at proposed location of 400 kV Tower No. 195

An environmental assessment and an evaluation has been carried out on an area around Tower 195 in which an underground cable will be routed to resolve the conflict between the proposed location of Tower 195 and the existing 10 kV overhead line. The area evaluated is detailed on Figure 3-8 below. This area is situated in the townland of Corvally, Co. Monaghan. The underground cable route starts at a line/cable interface structure position south of Tower 195 and will be routed to a line/cable interface structure north east of the proposed 400 kV structure.

Figure 3-8: 400 kV Tower 195 conflict

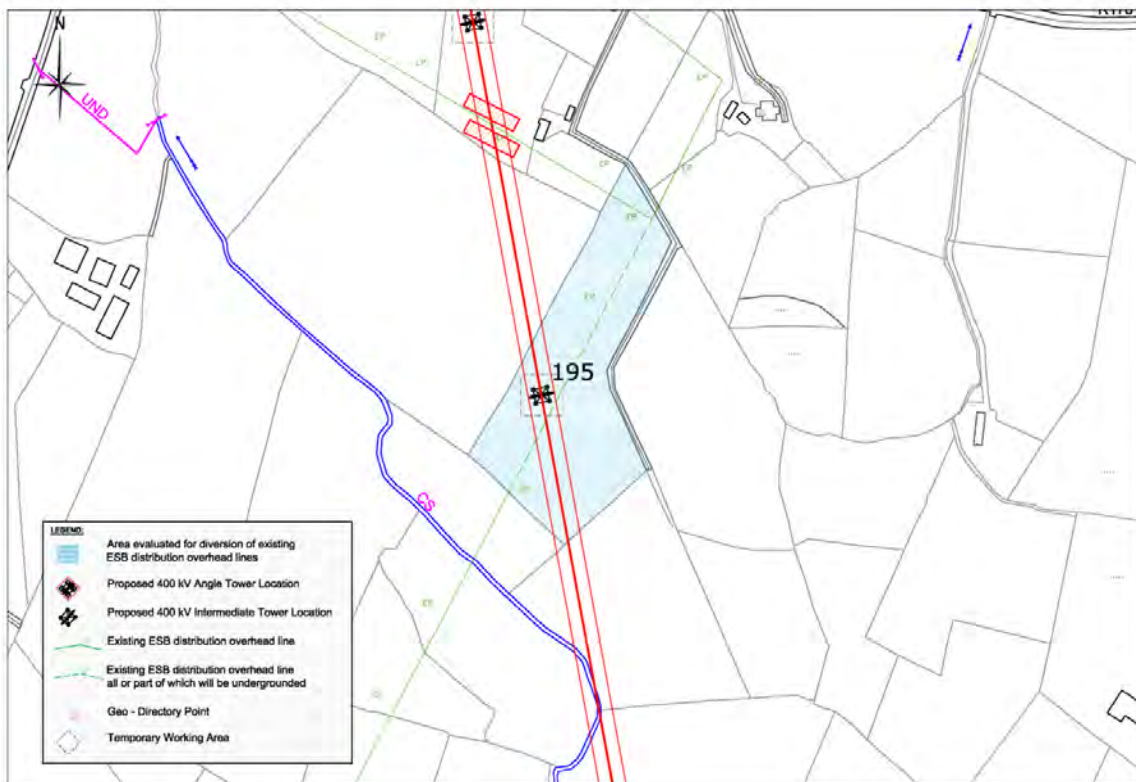

The area in the immediate vicinity of Tower 195 consists of improved grassland of low ecological value. The route will not affect any hedgerows on an upper slope of a drumlin, approx. 300m south from R178. Another nearby road is a local road located approx. 400m away to the west. Views from both of the roads will be generally screened due to topography of the terrain and existing vegetation.

According to the Monaghan Landscape Character Assessment, The underground cable zone is located within the Landscape Character Type 'Farmed Foothills' and within the Landscape Character Area 'Drumlin and Upland Farmland of South Monaghan'. The hinterland has poorly drained soils; subsoil classification - shale and sandstone till (Lower Palaeozoic). No major stream in the vicinity of the underground route.

There is a circular anomaly approximately 100m to the west of the existing OHL; the anomaly is described as a circular cropmark 60m in diameter. The cable route location is of low archaeological potential and there will be no direct impacts on the known cultural heritage resource.

Given the minor nature and scale of the works proposed within the area evaluated, which is improved grassland of low ecological value, with no greater visual impact, nor impact on the landscape character and removed from natural surface waters and known sites or monuments, there will be no significant impacts on the receiving environment.

3.2.8 Conflict at proposed location of 400 kV Tower No. 212

An environmental assessment and an evaluation has been carried out on an area around Tower 212 in which an underground cable will be routed to resolve the conflict between the proposed location of Tower 212 and the existing distribution lines. The area evaluated is detailed on Figure 3-9 below. This area is situated in the townland of Lisagoan, Co. Cavan. Three separate underground cable routes will be required commencing and terminating at line/cable interface structures, routed either north or south of the proposed 400 kV structure (Tower 212). These will pass through at least one hedgerow and possibly two hedgerows.

Figure 3-9: 400 kV Tower 212 conflict

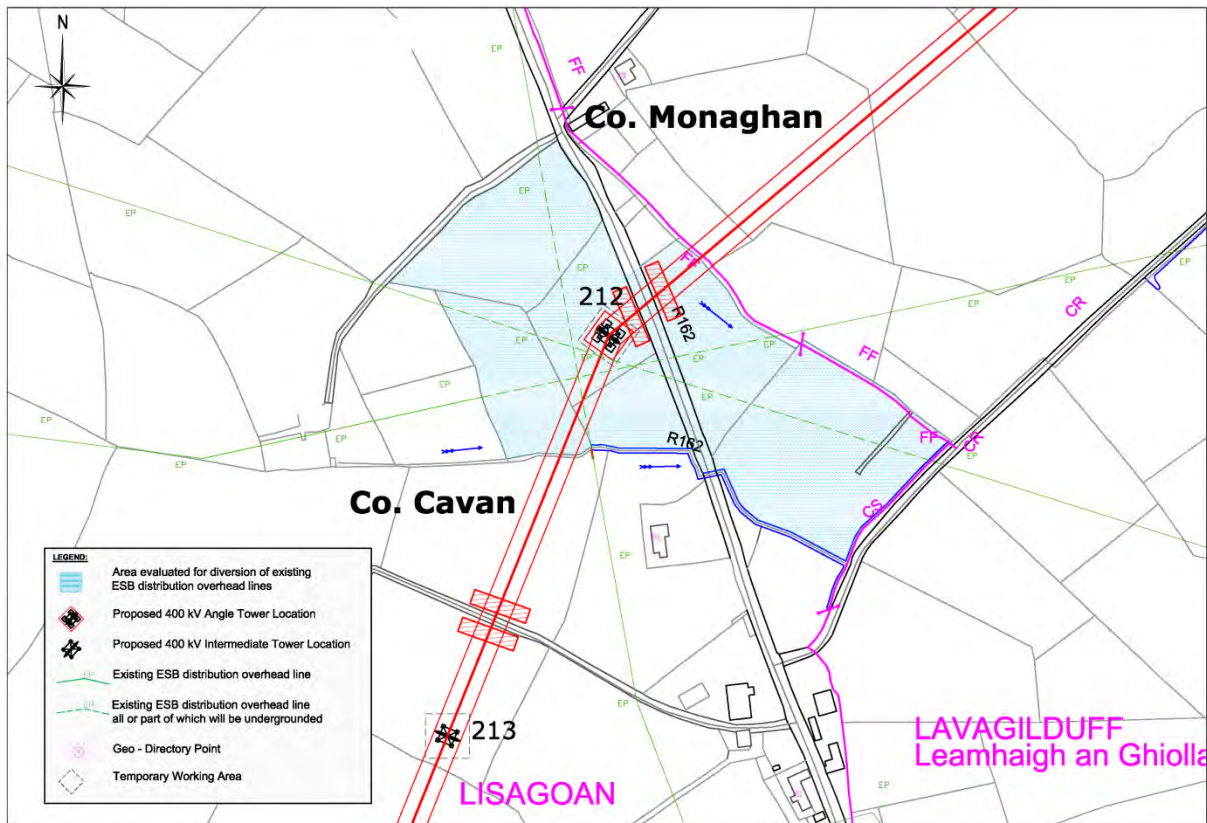

The area in the immediate vicinity of Tower 212 consists of semi-improved grassland of low ecological value. The route will start to the south east of Tower 212, to the east of the roadway. The tower is located in close proximity to a roadway in the south west corner of the field. The cable route will pass through a maximum of three hedgerows. The cable zone is of low archaeological potential and there will be no direct impacts on the known cultural heritage resource.

The nearest geo-directory point (dwelling) is approximately 75m away from the line and 125m from the tower. The line/cable interface tower to the east will be located in close proximity to the minor road network. Views of the line/cable interface structures from the local road will have no greater visual impact than the current standard single pole.

According to the Cavan Landscape Character Assessment, the routes are located within the 'Highlands of East Cavan' Landscape Character Area. The hinterland has poorly drained soils; subsoil classification - shale and sandstone till (Lower Palaeozoic). There are no major streams in the vicinity of the underground routes.

Given the minor nature and scale of the works proposed within the area evaluated, which is semi-improved grassland of low ecological value, with no greater visual impact, nor impact on the landscape character and removed from natural surface waters and known sites or monuments, there will be no significant impacts on the receiving environment.

3.2.9 Conflict at proposed location of 400 kV Tower No. 306

An environmental assessment and an evaluation has been carried out on an area around Tower 306 in which an underground cable will be routed to resolve the conflict between the proposed location of Tower 306 and the existing 20 kV overhead line. The area evaluated is detailed on Figure 3-10 below. This area is situated in the townland of Gibstown Demesne, Co. Meath. The underground cable route starts at a line/cable interface structure position west of Tower 306 and will be routed either north or south of the proposed 400 kV structure to a line/cable interface structure east of the proposed 400 kV structure.

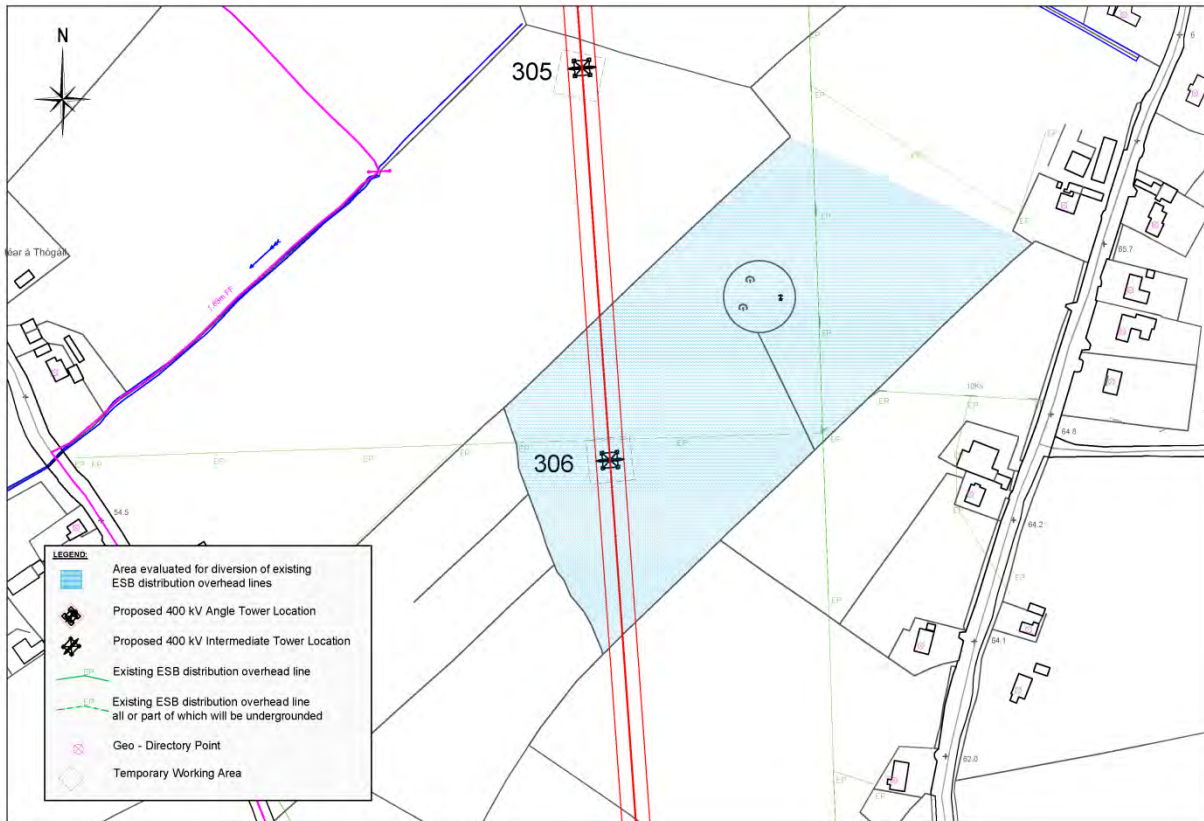
Figure 3-10: 400 kV Tower 306 conflict

The area in the vicinity of Tower 306 consists of improved grassland of low ecological value, however swan flight lines were recorded in this area during the 2010/2011 and 2011/2012 seasons. The area is situated within Gibstown Demesne (Main features unrecognisable - peripheral features visible). Between towers 306 and 305 there is an aerial anomaly identified as a circular feature with archaeological potential. An additional detailed desktop assessment of the Teltown ZAA was carried out and formulated in consultation with the DAHG. There is no recorded monument within the underground cable zone with the nearest in excess of 750m to the south east of Tower 306 and the tower is located over 1km from the site of Gibstown house and in excess of 250m from the demesne boundary. There will be no direct impact on the known cultural heritage resource. Tower 306 is located approximately 250m from a road to the east and approximately 300m from a road to the west within a network of fields and hedgerows. Views of the line/cable interface structures from the local road network will have no greater visual impact than the current standard single pole.

According to the Meath Landscape Character Assessment, the route is located in the 'Blackwater Valley Landscape Character Area' within the 'River Corridors and Estuaries Landscape Character Type'. This Landscape Character Area had been classified as Very High Landscape Value, Regional Importance and High Sensitivity. The location is approximately 10km away from the 'Tower at Kells' - Protected View of National Significance and approx. 2.5km away from Protected View 80, as indicated in the Meath County Development Plan 2013 - 2019. The hinterland has dry deep acidic soils. Subsoil

classification - shale and sandstone till (Lower Palaeozoic). There are no major streams in the vicinity of the underground route.

Given the minor nature and scale of the works proposed within the area evaluated, which is improved grassland of low ecological value, with no greater visual impact, nor impact on the landscape character near on the swan flight lines and removed from natural surface waters and known sites or monuments. However a pre-construction survey would be undertaken to confirm current evaluation and based upon these results any direct impacts on sites of archaeological potential encountered would be avoided and thus, there will be no significant impacts on the receiving environment.

3.2.10 Conflict at proposed location of 400 kV Tower No. 313

An environmental assessment and an evaluation has been carried out on an area around Tower 313 in which an underground cable will be routed to resolve the conflict between the proposed location of Tower 313 and the existing 10 kV overhead line. The area evaluated is detailed on Figure 3-11 below. This area is situated in the townland of Castlemartin, Co. Meath. The underground cable route starts at a line/cable interface structure position north west of Tower 313 and will be routed to a line/cable interface structure east of the proposed 400 kV structure.

Figure 3-11: 400 kV Tower 313 conflict

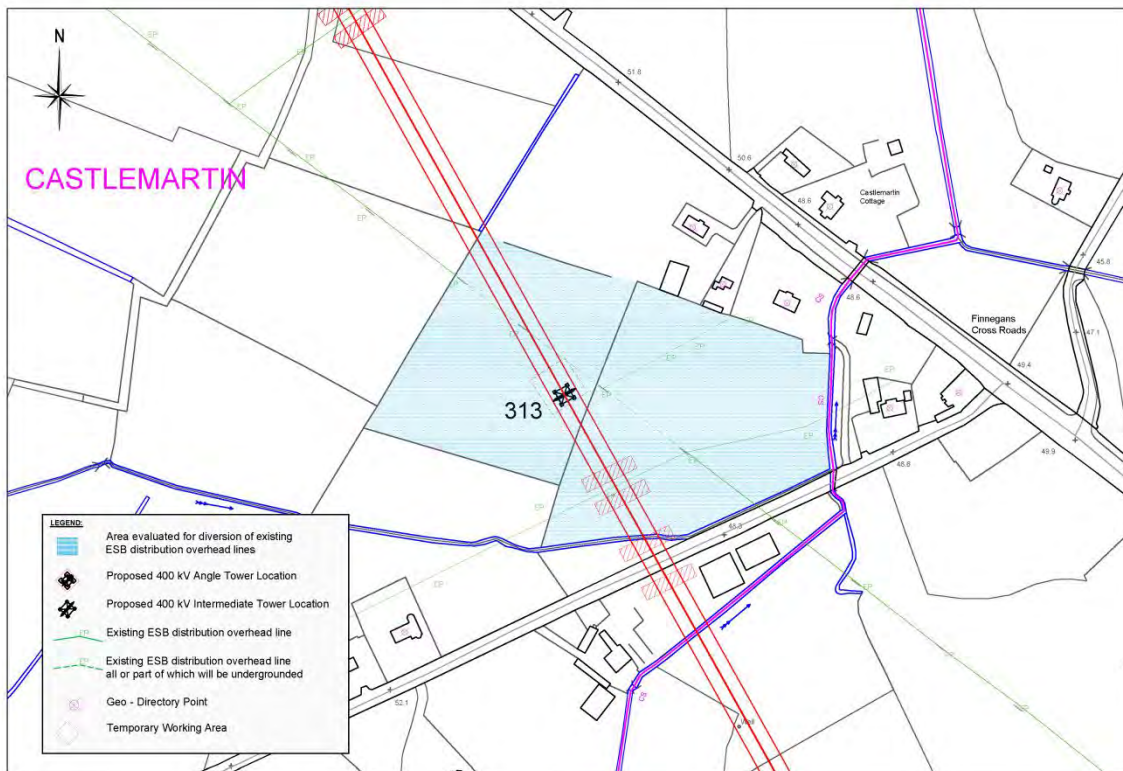

The area in the immediate vicinity of Tower 313 consists of improved grassland of low ecological value. The route will start to the north west of Tower 313 and it is likely to pass through one hedgerow on route to a line/cable interface structure to the south east. The cable zone is of low archaeological potential and there will be no direct impacts on the known cultural heritage resource.

Tower 313 is located approximately 135m and 190m from the road network which is to the south and east of the proposed structure. There are no recorded monuments and the route is located in excess of 500m from any recorded monuments, with low archaeological potential and there will be no direct impacts on the known cultural heritage resource. Views of the line/cable interface structures from the local road network will have no greater visual impact than the current standard single pole.

The area in which the underground cable zone is located has been described in the Meath Landscape Character Assessment as West Navan Lowlands Landscape Character Area within Lowland Landscapes. This Landscape Character Area is of moderate landscape value, local importance and of medium sensitivity as described in the Meath Landscape Character Assessment. The cable zone is located approximately 3km away from Protected View 80, as indicated in the Meath County Development Plan 2013 - 2019.

The hinterland has dry deep acidic soils, subsoil classification - shale and sandstone till (Lower Palaeozoic). There are no major streams in the vicinity of the underground route.

Given the minor nature and scale of the works proposed within the area evaluated, which is improved grassland of low ecological value, with no greater visual impact, nor impact on the landscape character and removed from natural surface waters and known sites or monuments, there will be no significant impacts on the receiving environment.

3.2.11 Conflict at proposed location of 400 kV Tower No. 334

An environmental assessment and an evaluation has been carried out on an area around Tower 334 in which an underground cable will be routed to resolve the conflict between the proposed location of Tower 334 and the two existing 10 kV overhead lines. The area evaluated is detailed on Figure 3-12 below. This area is situated in the townland of Irishtown, Co. Meath.

The area in the immediate vicinity of Tower 334 consists of improved grassland of low ecological value and the UGC will likely pass through a maximum of two hedgerows each. The cable zone is located in excess of 250m from a thatched house. The zone is of low archaeological potential and there will be no direct impacts on the known cultural heritage resource.

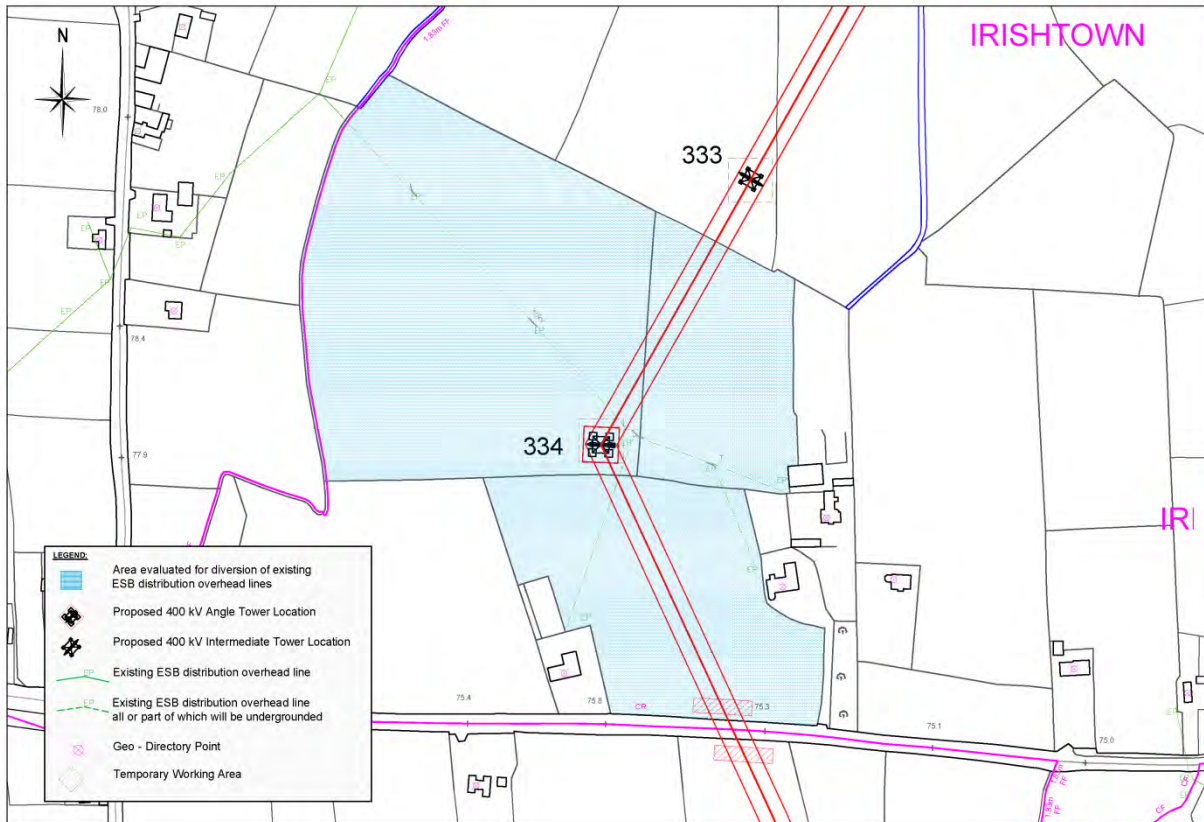
Figure 3-12: 400 kV Tower 334 conflict

The nearest geo-directory points (dwellings) are approximately 135m south and south west from Tower 334. A road runs approximately 150m to the south and the views of the line/cable interface structures will have no greater visual impact than the current standard single pole.

The area in which the underground cable zone is located has been described in the Meath Landscape Character Assessment as West Navan Lowlands Landscape Character Area within Lowland Landscapes. This Landscape Character Area is of moderate landscape value, local importance and of medium sensitivity as described in the Meath Landscape Character Assessment. The hinterland has poorly drained deep basic soils, subsoil classification - limestone till. There are no major streams in the vicinity of the underground route.

Given the minor nature and scale of the works proposed within the area evaluated, which is improved grassland of low ecological value, with no greater visual impact, nor impact on the landscape character and removed from natural surface waters and known sites or monuments, there will be no significant impacts on the receiving environment.

4 OVERHEAD TELECOMMUNICATIONS LINE CROSSINGS

4.1 CONSTRUCTION METHODOLOGY

There are 59 roadside locations where the proposed overhead line crosses existing telecommunication lines. The telecommunication lines will be undergrounded by Eircom and placed under public roads before the 400 kV overhead line construction takes place at the relevant locations.

All telecommunications lines traversing a transmission line route are undergrounded to a minimum distance of the highest adjacent 400 kV structure plus 1.0m either side of the 400 kV route. Figure 4-1 below is an excerpt from Eircom design instructions which illustrates the distance requirements they apply when undergrounding their infrastructure under an existing or proposed transmission line route. Taking a tower height of 43m, this would require an Eircom line traversing an adjoining span to be undergrounded a minimum of 44m either side of the 400 kV route resulting in an overall undergrounding distance of a minimum of 88m. For the purposes of the environmental impact evaluation, a 100mm duct trench width and 600 mm depth is considered. In a significant number of instances the proposed cabling will run along existing roads. A single woodpole structure with one stay is to be considered at either end of the undergrounded Eircom line.

Figure 4-1: Illustration of Eircom undergrounding practice at a transmission line crossings

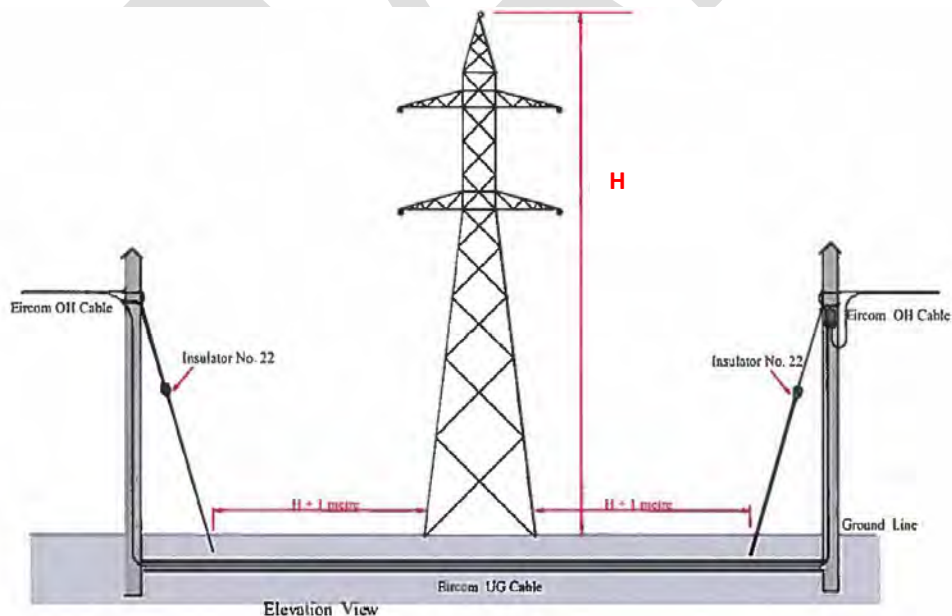

All telecommunications line alterations will be completed, by Eircom, in advance of the relevant 400 kV structures being constructed and as such these works do not form part of the overall planning application.

4.2 LINE CROSSING LOCATIONS AND EVALUATION

As outlined above there are 59 roadside locations where the proposed 400 kV route crosses existing overhead telecommunications lines. These lines will be undergrounded by Eircom to a set distance either side of the 400 kV route prior to the 400 kV circuit being energised. These works may result in temporary lane or road closures, but will be scheduled to be undertaken in advance of the proposed 400 kV construction stage. There are therefore no potential cumulative traffic impacts.

The affected sections are located where the proposed 400 kV route traverses public roads and are identified in the follow locations:

- Span 109-110 adjacent to roadway in townland of Lisdrumgormly, Co. Monaghan;
- Span 115-116 adjacent to roadway in townland of Tassan, Co. Monaghan;
- Span 150-151 adjacent to roadway in townland of Drumhawan, Co. Monaghan;
- Span 124-125 adjacent to roadway in townland of Annagh (Cremorne By), Co. Monaghan;
- Span 131-132 adjacent to roadway in townland of Drumroosk, Co. Monaghan;
- Span 136-137 adjacent to L3403 roadway in townland of Cornanure, Co. Monaghan;
- Span 143-144 adjacent to roadway in townland of Cornmucklagh South, Co. Monaghan;
- Span 157-158 adjacent to roadway in townland of Greagh (Cremorne By), Co. Monaghan;
- Span 162-163 adjacent to R180 roadway in townland of Brackly (Cremorne By), Co. Monaghan;
- Span 165-166 adjacent to roadway in townland of Boraghy, Co. Monaghan;
- Span 167-168 adjacent to roadway in townland of Drumillard, Co. Monaghan;
- Span 169-170 adjacent to R181 roadway in townland of Tooa, Co. Monaghan;
- Span 178-179 adjacent to roadway in townland of Cornasassonagh, Co. Monaghan;
- Span 181-182 adjacent to roadway in townland of Ummerafree, Co. Monaghan;
- Span 183-184 adjacent to roadway in townland of Ummerafree, Co. Monaghan;
- Span 185-186 adjacent to roadway in townland of Ummerafree, Co. Monaghan;
- Span 186-187 adjacent to roadway in townland of Sreenty, Co. Monaghan;

-
- Span 192-193 adjacent to roadway in townland of Ardragh, Co. Monaghan;
 - Span 193-194 adjacent to R178 roadway in townland of Corvally (Farney By), Co. Monaghan;
 - Span 196-197 adjacent to roadway in townland of Raferagh, Co. Monaghan;
 - Span 199-200 adjacent to roadway in townland of Raferagh, Co. Monaghan;
 - Span 199-200 adjacent to roadway in townland of Raferagh, Co. Monaghan;
 - Span 217-218 adjacent to roadway in townland of Corlea (Clankee By), Co. Cavan;
 - Span 221-222 adjacent to roadway in townland of Corglass (ED Lisnagoan), Co. Cavan;
 - Span 224-225 adjacent to R165 roadway in townland of Corrycholman, Co. Cavan;
 - Span 226-227 adjacent to roadway in townland of Leiter (ED Lisagoan), Co. Cavan;
 - Span 227-228 adjacent to roadway in townland of Cordoagh (ED Enniskeen), Co. Cavan;
 - Span 228-229 adjacent to roadway in townland of Cordoagh (ED Enniskeen), Co. Cavan;
 - Span 237-238 adjacent to roadway in townland of Cordoagh, Co. Cavan;
 - Span 239-240 adjacent to roadway in townland of Boherlea, Co. Meath;
 - Span 244-245 adjacent to roadway in townland of Tullyweel, Co. Meath;
 - Span 249-250 adjacent to roadway in townland of Aghamore, Co. Meath;
 - Span 251-252 adjacent to roadway in townland of Aghamore, Co. Meath;
 - Span 253-254 adjacent to roadway in townland of Towas, Co. Meath;
 - Span 253-254 adjacent to roadway in townland of Towas, Co. Meath;
 - Span 261-262 adjacent to roadway in townland of Cruicetown, Co. Meath;
 - Span 262-263 adjacent to roadway in townland of Altmush (E.D. Cruicetown), Co. Meath;
 - Span 267-268 adjacent to roadway in townland of Brittas, Co. Meath;
 - Span 272-273 adjacent to roadway in townland of Rahood, Co. Meath;
 - Span 280-281 adjacent to roadway in townland of Clooney, Co. Meath;

-
- Span 283-284 adjacent to roadway in townland of Drakerath, Co. Meath;
 - Span 291-292 adjacent to roadway in townland of Fletcherstown, Co. Meath;
 - Span 298-299 adjacent to roadway in townland of Baile Órthaí (Oristown), Co. Meath;
 - Span 302-303 adjacent to R163 roadway in townland of Baile Órthaí (Oristown), Co. Meath;
 - Span 309-310 adjacent to roadway in townland of Tailtin (Teltown), Co. Meath;
 - Span 311-312 adjacent to R147 roadway in townland of Castlemartin, Co. Meath;
 - Span 313-314 adjacent to roadway in townland of Castlemartin, Co. Meath;
 - Span 317-318 adjacent to roadway in townland of Tankardstown (E.D. Ardraccan), Co. Meath;
 - Span 325-326 adjacent to roadway in townland of Neillstown (E.D. Ardraccan), Co. Meath;
 - Span 327-328 adjacent to roadway in townland of Neillstown (E.D. Ardraccan) Co. Meath;
 - Span 334-335 adjacent to N51 roadway in townland of Irishtown (E.D. Ardraccan), Co. Meath;
 - Span 339-340 adjacent to roadway in townland of Churchtown, Co. Meath;
 - Span 353-354 adjacent to R161 roadway in townland of Dunganny, Co. Meath;
 - Span 357-358 adjacent to roadway in townland of Trubley, Co. Meath;
 - Span 363-364 adjacent to roadway in townland of Knockstown (E.D. Kilcooly), Co. Meath;
 - Span 369-370 adjacent to roadway in townland of Crumpstown or Marshallstown (E.D. Galtrim), Co. Meath;
 - Span 380-381 adjacent to roadway in townland of Martinstown (E.D. Galtrim), Co. Meath;
 - Span 387-388 adjacent to roadway in townland of Derrypatrick, Co. Meath;
 - Span 400-401 adjacent to R125 roadway in townland of Woodtown, Co. Meath.

The undergrounding works will be undertaken by Eircom in accordance with their standard construction methodologies and the effects of the proposed line crossings works on the environmental aspects of the areas identified will therefore not result in significant adverse effects. Residual effects would therefore be minor adverse or negligible. As a result there are no potential adverse cumulative impacts.

5 CONCLUSIONS

As requested by An Bord Pleanála the report identifies the locations where re-routing of existing overhead lines will be required at points where the proposed 400 kV line route traverses the following three categories of overhead line infrastructure, namely:

- Electricity Transmission Lines (220 kV, 110 kV);
- Electricity Distribution Lines (38 kV, 20 kV, 10 kV and LV (Low Voltage) lines); and,
- Overhead Telecommunication Lines

The proposed specific works for each of those three separate line types are detailed and an environmental evaluation of the proposed works is undertaken.

The requirement for works to the existing transmission and distribution systems has the potential for significant adverse effects, particularly on the ecological interests of the area.

The line crossing works will be undertaken in accordance with the mitigation measures proposed for the construction of the overhead line generally, in so far as these would be applicable to these smaller elements of construction (refer to **Table 11.1** of **Volume 3B** of the EIS).

Given the nature and scale of the proposed works, these line crossings works would not be expected to give rise to significant adverse effects on the environment of the area. Furthermore, these works would not result in any adverse effects to the integrity of any European Sites, as defined by the conservation objectives and status of those sites.

ANNEXES

- ANNEX A-1: ESBN'S 110 KV LIVE WORKING PROCEDURE (LWP
11008)**
- ANNEX A-2: ESBN'S STANDARD SPECIFICATIONS FOR ESB LV/MV
DUCTING**
- ANNEX A-3: ESBN'S STANDARD SPECIFICATIONS FOR ESB 38 KV
DUCTING/CABLING**
-

DRAFT

ANNEX A-1:

**ESBN'S 110 KV LIVE WORKING PROCEDURE (LWP
11008)**

110kV LIVE WORKING PROCEDURE

LWP 11008

TITLE

How to Install a Pole in a 110kV Circuit Using a Pole Erector (Circuit Energized)

Approved: *James W. Higgins* Date: 10/3/1996
Manager, Distribution Department

Review Date: March 2001

Contents

1. Safety Summary 3
 1.1 Identified Hazards 3
2. Tools and Equipment 4
3. Procedure
 3.1 Preliminary Work 4
 3.2 New Hole Installation 5
 3.3 Existing Hole Installation using Platform Method 7
 3.4 Existing Hole Installation using Pole Erector to move Pole to Existing Hole 8

DRAFT

1. Safety Summary

The following hazards and precautions are emphasised to highlight some of the safety considerations related to this job. Other hazards which are site specific and of a general nature must be identified during the tailboard conference before the work begins.

1.1 Identified Hazards Associated with Live Line Work

Precautions For Electrical Hazards

- Confirm that the auto recloser has been rendered inoperative.
- Maintain limits of approach for personnel on 110kV circuit.
- Temporarily earth the Pole Erector to best available ground.
- All personnel must remain clear of the Pole Erector while the pole is being installed.
- The operator of the Pole Erector must remain on the vehicle and maintain positive control at all times.
- Take protective measures against inadvertent voltages while handling ropes.
- The signal person must have clear field of view to the operator and the pole being installed.

Precautions for Mechanical Hazards

- The signal person must stand out of the falling distance of the pole being installed.
- All non-essential personnel and public must be kept clear of the work area.
- The Pole Erector must be capable of installing new poles of 20 metres or less in good ground conditions.
- Where the new pole being installed is greater than 20 metres long, or where site conditions dictate otherwise, use a Tractor Winch and Excavator to raise the pole. (See procedure LWP-11001).

Working Aloft

- Use approved fall protection while working aloft.

Communications

- Good verbal communication is required of all crew members.

2. Tools and Equipment

- 1 - Excavator fitted with Pole Erector (capable of installing the new

pole up to 20 metres long)

- Temporary anchors or holdfasts for temporary staying
- 1 - Power chain saw and associated safety equipment
- Timbers as required for the temporary base if the pole is to be cut off and moved
- Assortment of ropes for temporary stays, lashing and directing the butt of the new pole

3. Procedure

3.1 Preliminary Work

Step	Action
1	Conduct a tailboard conference.
2	Inspect the work structure and the adjacent structures and secure poles using temporary stays as required.
3	Confirm that the auto recloser has been rendered inoperative on the circuit.
4	When not using the original hole location, set up the excavator to dig a new hole in line with the existing structure.
5	If the new pole is to be set in the existing location, the old pole will have to be moved and its butt pulled out of the original hole. (See item 3.3. Platform Method and 3.4 Pole Erector Method).

3.2 New Hole Installation

Step	Action
1	Pick up the new pole at balance point and fit the safety chains to the pole

clamping arms. Park the pole over the cab of the Pole Erector in the horizontal position. (Fig. 1).

- 2 Drive the Pole Erector into position in line with the existing pole. Set up and temporarily earth the machine.
- 3 Raise the new pole slowly while being directed by a signal person. Maintain

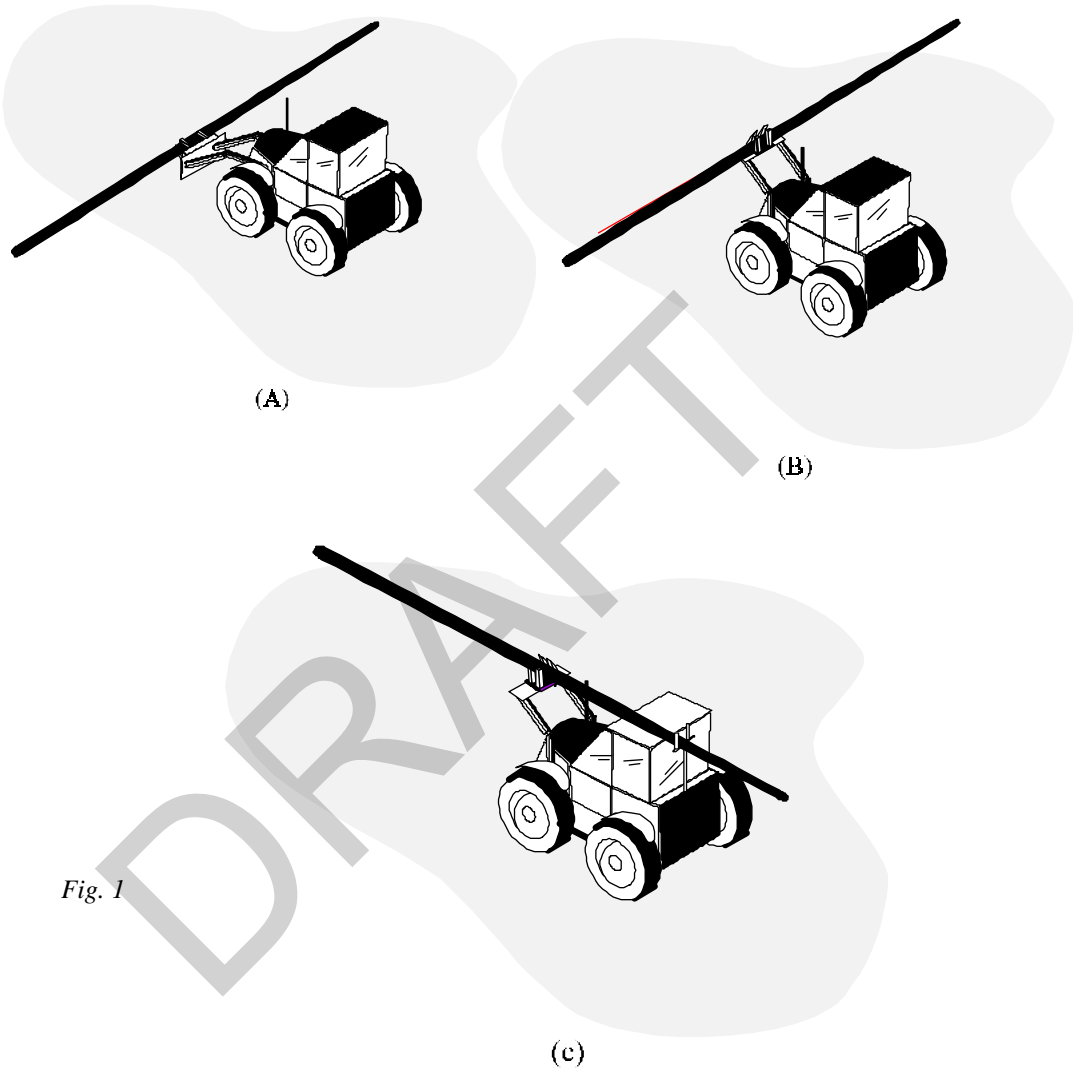

Fig. 1

approximately equal clearance from the energised conductors on either side. (Fig. 2).

- 4 Set the pole in the hole.
- 5 Turn the pole to face the same direction as the old pole.
- 6 After straightening the pole, secure temporarily to old pole, backfill and tamp.

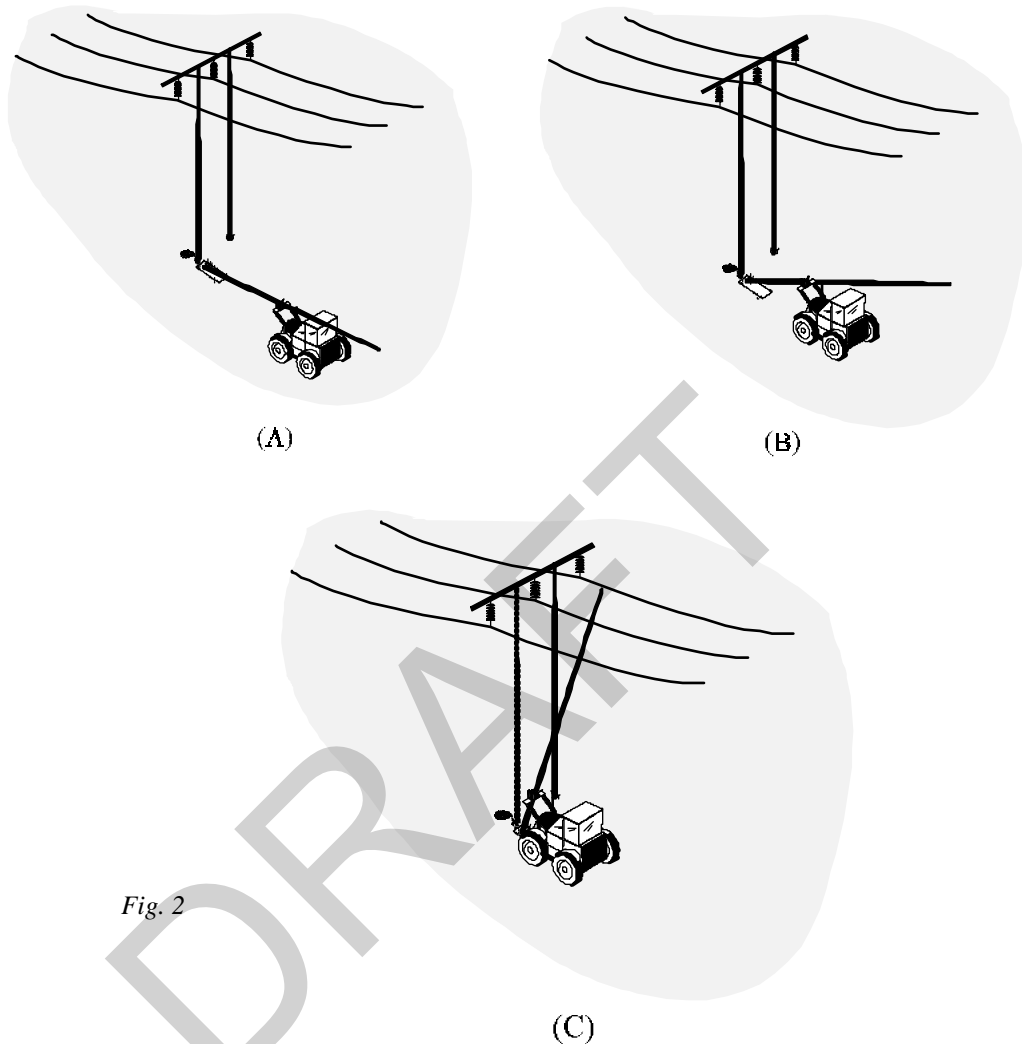

Fig. 2

- 7 Lash the new and old poles together until the attachments are transferred. After transfers are made prepare to remove old pole.
- 8 Cut off the top of the pole in sections that can be easily handled with ropes until it is below the conductor level. Cut remainder of pole down. Remove the pole butt with the excavator.

3.3 Existing Hole Installation using Platform Method

Step	Action
1	If the other pole of the structure and the crossarm are in good condition, side stays are not required.

- 2 Lash timbers together for a temporary base and locate it immediately adjacent to the existing pole. (Fig. 3)
- 3 Attach three or four rope stays to the existing pole above the ground line. These stays will be used to steady the existing pole on the base.
- 4 Set up and temporarily earth the Pole Erector in a position to hold the existing pole and to allow moving the butt onto the temporary base.

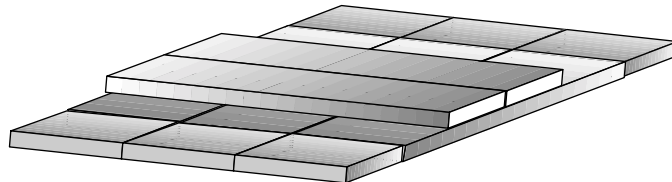

Fig. 3

- 5 Cut off the old pole while holding it with the Pole Erector and the rope stays. (Fig. 4)
- 6 Move the old pole onto the temporary base using the Pole Erector and the rope stays attached near the ground line.
- 7 Tighten the rope stays on the butt and remove the Pole Erector from the old

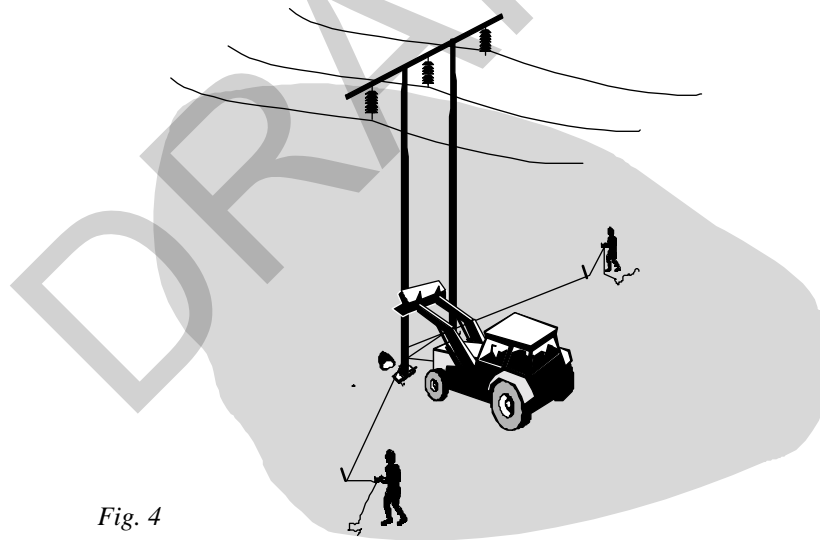

Fig. 4

pole.

- 8 Remove the old butt and clean out the hole to allow setting of the new pole.
- 9 Install the new pole as per the installation in Section 3.2 above.
- 10 Confirm the auto recloser may be restored on the circuit.

3.4 Existing Hole Installation using Pole Erector to move Pole to Existing Hole

Step	Action
1	If the other pole of the structure and the crossarm are in good condition, side stays are not required.
2	Excavate hole in line beside existing pole.
3	Pick up the new pole at balance point and fit the safety chains to the pole clamping arms. Park the pole over the cab of the Pole Erector in the horizontal position. (Fig. 1)
4	Drive the Pole Erector into position in line with the existing pole. Set up and temporarily earth the machine.
5	Raise the new pole slowly while being directed by a signal person. Maintain approximately equal clearance from the energised conductors on either side (Fig. 2)
6	Set the pole in the hole.
7	Turn the pole to face the same direction as the old pole.
8	After straightening the pole, secure temporarily to old pole, and temporarily stay new pole in 3 directions.
9	Lash the new and old poles together and transfer crossarm to new pole, remove lashing. New pole temporary stays must remain.
10	Cut off top of old pole in sections that can be easily handled with ropes until it is below the conductor level. Cut the remainder of pole down. Remove the pole butt with the excavator.
11	Pick up the new pole with pole erector and place in existing hole. (Fig. 5)
12	Backfill hole and remove temporary stays from new pole.

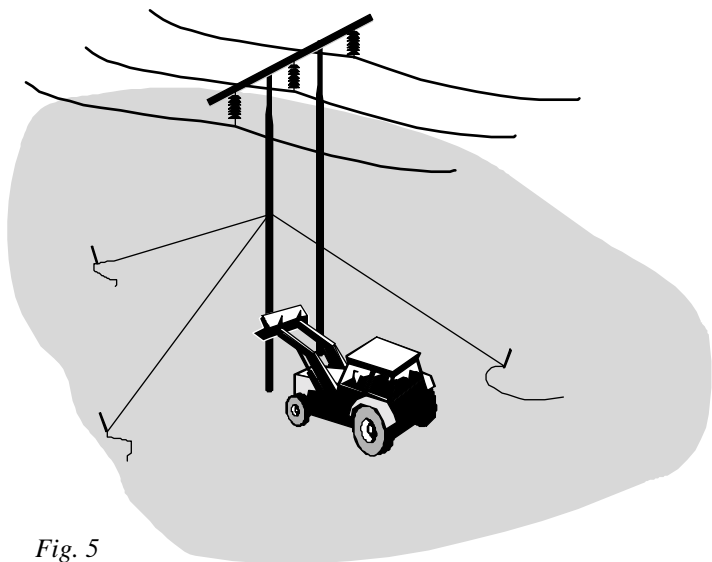

DRAFT

ANNEX A-2:

**ESBN'S STANDARD SPECIFICATIONS FOR ESB LV/MV
DUCTING**

Standard Specification for ESB MV/LV Networks Ducting (Minimum Standards)

ESB Networks
 Drg. No. NW-014
 Rev 0: Date 09-08
 Approved:

Note 1: ESB Networks reserves the right not to accept ducting which does not conform to these standards and dimensions
 Note 2: Refer to ESB Networks for Specific job Specification. These instructions do not apply to 38kV/110kV/220kV cable
 Note 3: All materials (ducts, marker tapes/strips, duct surrounds, mandrels and brushes) must be ESB approved materials

1 MINIMUM depths below finished ground level

DEPTH

- 450mm in established footways
- 600mm in new housing estate carriageways & footways and all grassed areas
- 750mm All Non-Housing Estate carriageways, forestry farmland & bogland

Depth is measured to top of duct
 Max depth is 1m except at:

- service crossings where 1.5m is allowed
- short rail and road crossings where up to 2.5m is allowed

2A Minimum Standard Clearances to Other Services

Clearance to Normal Services: 300mm

Clearance to: Large Pipelines High Pressure Pipes: 600mm

- To achieve these clearances see sections 3D and 3E below
- Clearances less than the above at pinch points and crossings requires placement of additional mechanical protection (concrete slab/brick) and agreement of ESB
- ESB ducts must never be laid over other services on parallel runs, except with the written prior agreement of the other utilities and ESB
- Other Services must never be laid directly over ESB ducts on parallel runs

2B Trench Installation Sequence

1 Examples of Unacceptable Routes: Roadway, Forest Roadway

2 Excavate trench to required dimensions. Ensure loose material and protruding stones are removed

3 Lay in & compact a bedding layer of approved material to a min thickness of 50mm or as otherwise specified

4 Lay ducts and horizontal spacer on 50mm bedding layer maintaining specified clearances

5 For multiple circuits ensure ducts are spaced as per Section 3 below with a min of 150mm duct spacing

6 Lay in and compact a layer of approved backfill to a depth of 200/275mm above bedding layer

7 Install ESB approved red marker strip on top of approved compacted backfill

8 Lay in and compact a layer of approved backfill maintaining a max depth of 300mm to the surface

9 Install ESB approved yellow marker tape. The max depth for the marker tape is 300mm from finished ground level

10 Reinstate final layer of backfill as per agreed LALand Owner Specification

3A Minimum Duct Spacings for ESB Ducts

75mm minimum duct spacing for up to two ducts in any layer

Duct crossovers not allowed at any point along route.

3B Minimum Duct Spacings for ESB Ducts

150mm duct spacing required for more than 2 ducts in any layer

Duct crossovers not allowed at any point along route.

3C Minimum Duct Spacings for ESB Ducts

Minimum duct to trench wall clearances and minimum bedding depths

Minimum duct to trench edge clearance is 100mm and minimum bedding depth is 50mm

NB: 50mm minimum depth of compacted approved backfill above duct top

3D Minimum Duct Spacings for ESB Ducts

Achievement of Horizontal Duct Spacing

Use 75mm or 150mm temporary timber/brick or plastic spacers as appropriate to establish horizontal duct spacing during construction

NB Use 300mm or 600mm horizontal spacers to achieve horizontal spacing from other utilities as appropriate

Always keep a stock of 300mm, 150mm & 75mm spacers for ESB Trenching

3E Minimum Duct Spacings for ESB Ducts

Achievement of Vertical Duct Spacing

STEP 1 Lay in Ducts and horizontal spacer Lay in 50mm bedding Layer

Step 2 Lay in and compact approved backfill to 200/275mm depth depending on spacing in 3A/3B above

Step 3 Check depth of approved backfill above 1st duct layer and lay in 2nd layer of ducts and spacers on top of sand layer

NB. Vertical Duct Spacers are not allowed anywhere as they create point loading of ducts. Refer to 3A/3B for spacings in specific situations

4A Installation of: Special ESB marked Yellow Marker Tape and Special ESB marked Red Marker Strip in Carriageways

ESB yellow marker tape and red marker strip is to be used on all carriageways and on grassed areas for both LV & MV cables

300mm Maximum for ESB yellow marker tape

75mm minimum above duct for ESB red marker strip.

ESB yellow marker tape and red marker strip widths must always be wider than ducts beneath

ESB yellow marker tape and ESB red marker strip must never be laid directly on top of ducts

Never lay other utility marker tape or strip over ESB ducts

Never lay ESB marker tape or strip over other utility pipes

4B Installation of Special ESB marked Yellow Marker Tape in all Footways

ESB approved yellow marker tape to be used on all Footways

300mm Maximum for ESB yellow marker tape

ESB yellow marker tape width must always be wider than width of ducts beneath

ESB Yellow marker tape must never be laid directly on top of ducts

Never lay other utility marker tape or strip over ESB ducts

Never lay ESB marker tape or strip over other utility pipes

CAUTION
ELECTRIC CABLE

5 Specification for duct surround material

The thermal resistivity of the duct surround material must be maximum 1.0km/watt @0% moisture content. Only ESB approved unwashed sand graded to BS882 standard or equivalent ESB approved material is acceptable.

Duct surround material must be well compacted around ducts without damaging the ducts

NB: Pea gravel and foam concrete are unacceptable ESB duct surround materials

6A Specification for Installation of Ducts at sharp route bends

ESB Approved Long Radius Bend (minimum Duct Bend Radius 1.2 Metres) Bends less than 1.2 m radius are unacceptable

400mm 10N Minimum strength concrete on inside of bend to withstand cable pulling forces

Wider trench to accommodate 400mm of concrete on inside of bend

Normal Trench Width

Cross Section at bend Showing concrete support all around the duct and increased trench width

6B Specification for Installation of Ducts at Gentle sweep bend positions

6m length straight pipe

Always use a series of 11, 22 or 45° bends to provide a smooth joint interface where the trench route curves around in a large sweep. Never bend ducts around a large sweep trench

Concrete support as for item 6A

7 Obligation of Duct Installer to minimise the number and severity of duct bends

The duct installer must minimise the number and severity of preformed bends in ground with obstructions and other utility service crossings by opening ground 12m ahead of backfilled duct, wherever practical to do so. This safety obligation, which may require use of steel plating, allows the duct installer to pick the least bendy duct route through utility crossings and obstructions. Otherwise, numerous sharp unrecorded duct route deviations will be present making cable installation considerably more difficult and less safe for the cable installer.

Backfilled Duct

Obstructions

Digger

Dig 12m Ahead of duct to uncover obstructions

8 Standard for Brushing, Mandrelling Roping and End-capping of MV/LV Ducts

All Ducts must be:

- Thoroughly brushed and mandrelled to prove ducts against debris/excessive deflection
- Roped using 12mm polypropylene rope with certified safe breaking load of 1.5 tons – all rope joints to be properly spliced and PVC taped over. Approved Supplier Silver Strand Bunclana Donegal, ph (074) 9382503 - 500m drum lengths available to minimise splicing/coil handling
- Sealed using endcaps against grit and water getting into them

NB: Replace mandrels once mandrel wear indicators or grooves are worn down

Replace brushes once brush diameter falls 5mm below dimensions in table below

- Approved endcaps, both disposable and reusable types, are available from suppliers of approved ESB ducting
- Approved ESB Mandrel and brush suppliers

Brandon Agencies, Rathnew, Co Wicklow. Phone 0404 20500 (Brushes & Mandrels)

15 Varian, Greenhills Industrial Estate, Walkinstown, Dublin 12. Phone: 01-4501150 (Brushes Only)

Clydesdale UK Phone 086 172 6665 (Brushes & Mandrels)

Tynagh Network Systems, Loughrea, Co Galway. Phone: 091 842206 (Brushes & Mandrels)

125mm uPVC Duct Size		160mm uPVC Duct Size	
Mandrel	Brush	Mandrel	Brush
Code: 9317547	Code: 8783254	Code: 9317548	Code: 8783251

9 Guidance on Correct Direction to Lay Spigot and Socket Ducting

Case 1 Duct run with all bends at one end

Correct direction as cable drum will be located at bendy end

Case 2 (a) Bendy no matter which side route is looked at
No best direction to lay ducts

Case 2 (b) More bends at one end than the other
Correct direction

Case 3 Trenching routes longer than 500m

Treat any route as a series of lengths between joint bays at say 500m intervals and lay ducting as for Case 1 & 2 above

If on large sloping route lay as shown

10 Approved ESB Ducting for MV/LV Cables

- Use only solid wall high impact resistance ESB approved PVC red ducting to IS 370 colour standard and ESB specification 16113 (3.8mm minimum wall thickness) Discoloured or unidentified ducting not acceptable. All duct material must be approved by ESB Networks.
- Lightweight flexible corrugated twinwall ducting is not acceptable to ESB irrespective of manufacturer
- Current approved Duct and duct bend manufacturers are: Lynplast (bend fittings only) Radius Systems, Wavin, Quality Plastics, MFP Plastics, Cork Plastics, Emtelle

11 Specification for Duct Jointing for MV/LV Cables

All ducts to be securely jointed by tapping against timber board on each duct until the black depth insertion mark is reached

12 Repair of Existing Ducts

Use only approved slip couplers from approved manufacturers in section 9

- Cut out damaged section of duct and ensure all cut surfaces are square and free from sharp edges
- Slide, position and centre the repair couplers on the centering marks

13 Sealing of Ducts

All ducts to be permanently sealed at both ends of duct run
Ducts to be temporarily sealed during installation using endcaps provided with each bale

ESB Code 125mm: 9317583 ESB Code 160mm: 9317566

14A Cross-Sectional Drawing of Backfilling in Front of MV Sub

SAFETY WARNING!!
Earths are an essential safety system. Connection will not be made available until they are installed.

See pg. 213 of MV/LV Manual

14B Plan View of Ducting in Front of Substation

See pg. 212 of MV/LV Manual

17A Supporting ESB Cables/Ducts During Trenching Works

See pg. 42 of MV/LV Manual

17B Supporting ESB Cables/Ducts During Trenching Works

See pg. 42 of MV/LV Manual

18 Avoidance of Cable Damage Due to Improper Backfilling at Cable Crossings

See pg. 44 of LV/MV Manual

19 MV/LV Trencher Dimensions & Duct Clearances for 125mm Ducting Layouts

Minimum Trench Widths for 1 & 2 Rows of Ducts

No. Of Ducts in Row	1	2	3	4	5	6
Minimum Trench Width	325	525	875	1150	1425	1700

Minimum Trench & Duct Depths for 1 Horizontal Row of Ducts

Location of Trench	New Housing Scheme Footpaths, road & Grass Areas in Vicinity	Existing Footpaths	Existing or New Roads Other Than New Housing Scheme	Farmland, Forestry tracks & England
Minimum Trench Depth (D)	775	625	925	925
Minimum Depth to top of Duct (E)	600	450	750	750

Minimum Trench & Duct Depths for 2 Horizontal Row of Ducts

Location of Trench	New Housing Scheme Footpaths, road & Grass Areas in Vicinity	Existing Footpaths	Existing or New Roads Other Than New Housing Scheme	Farmland, Forestry tracks & England
Minimum Trench Depth (D)	975	825	1125	1125
Minimum Depth to top of Duct (E)	1050	900	1200	1200
Minimum Depth to top of Duct (E)	600	450	750	750

20A Bridge Crossings: Restricted Footpath Designs

Cast Steel Marker Plate Code 3227172 cast flush with footpath surface at intervals of 2-4m. Alternatively bolted to bridge wall at similar intervals.

125mm uPVC ducts spaced 75mm apart with galvanised steel plates. ESB code 3227173 directly over each duct. These have markerstrip laminated to the steel. minimum 20 micron concrete to be placed between & above ducts. Ducts laid directly on bridge deck.

Galvanised steel or Stainless Steel Pipe Supported by cleats at 1m intervals. Minimum 4mm wall thickness. ESB marker plates code 3227172 to be fixed to pipe ends at both ends of bridge.

Telecom + other ducts on opposite footpath.

Bridge Abutment/Support

Alternative Position of cable

see pg. 167 of LV/MV manual

20B Bridge Crossings: Restricted Footpath Designs

- The design must be agreed with the bridge authority. Position in footpath is preferred.
- Minimum cover over ducts on footpath 100mm.
- Where duct cover is > 300mm, marker strip & surface marker plates can be used.
- Red uPVC ducting is not suitable for cable run external to bridges.
- Where possible galvanised steel/stainless steel piping should be used, all joints must be free of weld burrs on inside. Alternatively heavy duty 10mm wall thickness black HDPE material with cast steel marker plates attached must be used to permanently warn of presence of electric cable.

see pg. 167 of LV/MV manual

21A River/Stream Crossings: Standard Where Burial/Drilling is possible

Marker Post or Pole Stub with Sign

Yellow Marker Tape

Concrete will back from banks as this may be backfilled over time.

100mm Minimum

Minimum 200mm concrete surround

- Depth of burial below bottom of river or stream to be agreed with relevant authority (if applicable)
- If normal red ducting is installed by trenching, it must be encased in CBM4 (15N after 7 days) concrete to prevent uplift and to provide mechanical protection. Seal any joints to prevent concrete entering duct.
- If drilled crossing is practical use heavy red wall coated HDPE duct (sections 2.2 & 2.9 in MV/LV manual)
- Install an ESB marker post on both sides of the crossing - ESB code 8327355 or use stub pole minimum 2.0m above ground level & warning sign 8238339.
- Where circumstances require it a large steel pipe can be installed, into which a number of standard ESB duct sizes are pulled in (see section 2.8.4 of MV/LV manual for guidance)
- If crossing a tidal area, a foreshore licence will be required.

See pg. 168 of LV/MV manual

21B River/Stream Crossings: Standard Where Burial/Drilling is not possible

Marker Post or Pole Stub with Sign

Yellow Marker Tape

100mm Minimum Surround

- Installation on base of river or stream to be agreed with relevant authority (if applicable)
- Heavy wall steel pipe to be used free of weld beads/swarf. Minimum 8mm steel wall thickness to be used. Encase in CBM4 (15N after 7 days) concrete for corrosion protection, minimum 100mm surround
- Install an ESB marker post on both sides of the crossing - ESB code 8327355 or use stub pole minimum 2.0m above ground level & warning sign 8238339.
- Ensure a smooth connection using rubber coupler between crossing pipe size and ESB standard duct as the steel pipe size will usually differ from the standard ESB ducting. Alternatively run ESB ducting right through the steel pipe
- If crossing tidal area, a foreshore licence will be required.

See pg. 168 of LV/MV manual

22A Minimum Standard Over Basements/Carparks

ESB Surface Marker Plate

Min. 400mm

Min. 200mm

Standard Duct Separation & Spacing

ESB Surface Marker Plate

Structural Concrete Representation

Reinforced Concrete Slab Corner Detail

22B Minimum Standard Over Basements/Carparks

Minimum depth of duct is 400mm.

Minimum thickness from bottom of duct to underside of slab is 200mm.

ESB surface marker plates are to be placed at approximate intervals of 3 metres on the top and bottom surfaces of the slab.

Marker plates are to be cast level with the surface and screwed down to avoid lift off (ESB code: 3227172)

For ESB Ducts concrete surround - same strength for entire slab

23 MV/LV Trench Dimensions & Duct Clearances for 160mm Ducting

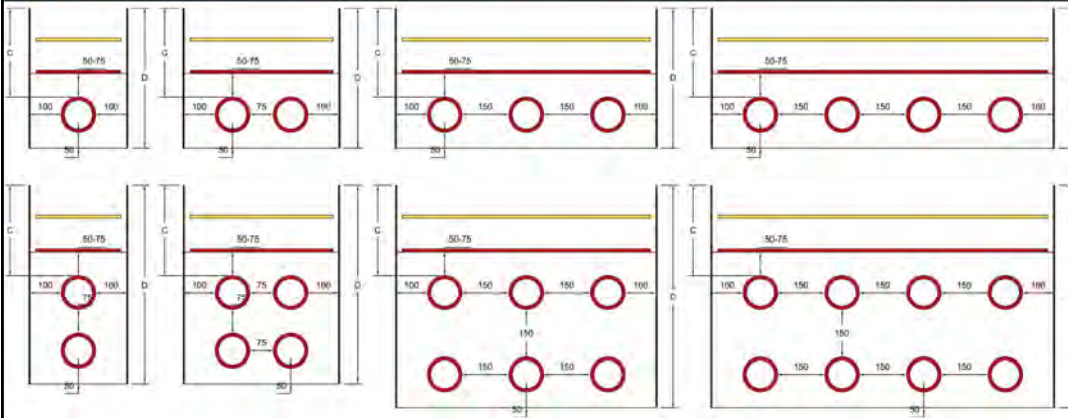

Minimum Trench Widths for 1 & 2 Rows of Ducts

No. Of Ducts in Row	1	2	3	4	5	6
Minimum Trench Width	360	595	980	1290	1600	1910

Minimum Trench & Duct Depths for 1 Horizontal Row of Ducts

Location of Trench	New Housing Scheme Footpath, road & Grass Areas in Vicinity	Existing Footpaths	Existing or New Roads Other Than New Housing Scheme	Farmland, Forestry tracks & Bogland
Minimum Trench Depth (D)	810	660	960	960
Minimum Depth to top of Duct (C)	600	450	750	750

Minimum Trench & Duct Depths for 2 Horizontal Row of Ducts

Location of Trench	New Housing Scheme Footpath, road & Grass Areas in Vicinity	Existing Footpaths	Existing or New Roads Other Than New Housing Scheme	Farmland, Forestry tracks & Bogland
Minimum Trench Depth (D)	1045	895	1195	1195
Minimum Depth to top of Duct (C)	1120	970	1270	1270
Minimum Depth to top of Duct (C)	600	450	750	750

24A MV Cable End Pole Position - Elevation

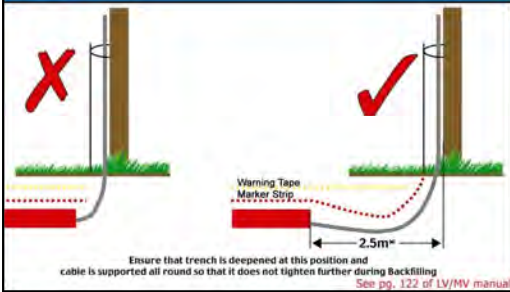

24B MV Cable End Pole Position - Plan View

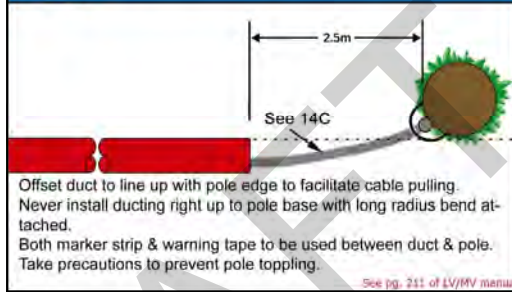

24C MV Cable End Pole - Marker Strip/Tape

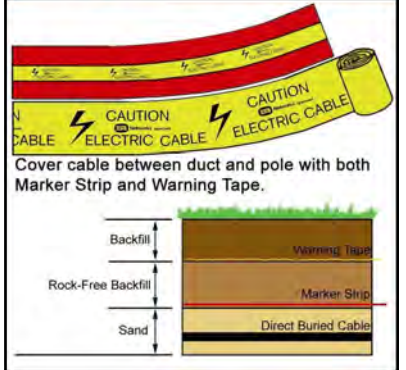

24D LV Cable End Pole Position - Elevation

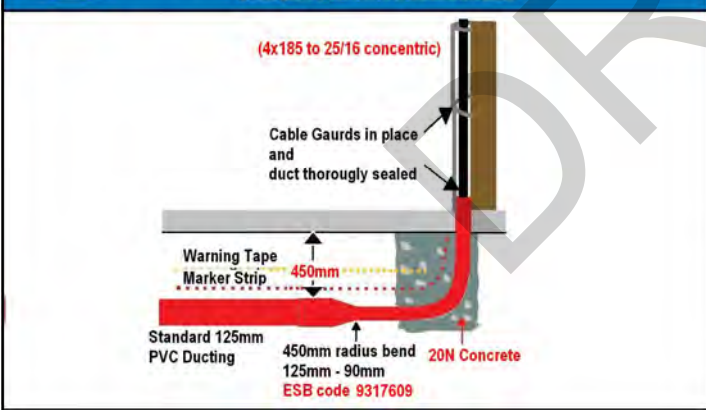

24E LV Cable End Pole Position - Plan View

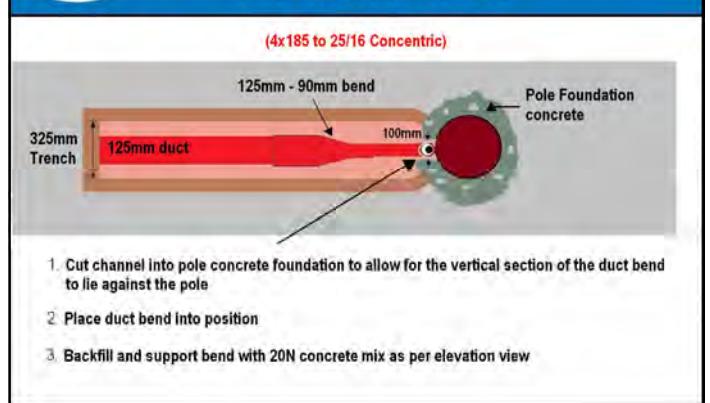

25 A LV Ducting for Non Domestic Connections Duct laid to Mains Cable

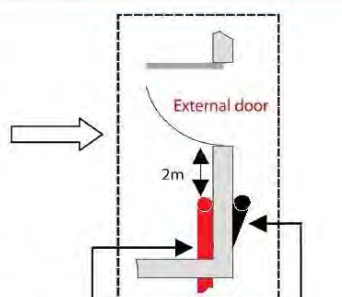
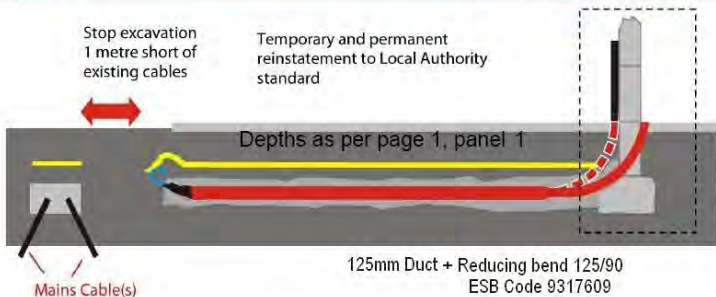

- General Note for all Cases:**
- Excavation within 1 metre of existing cables must only be carried out by hand and with agreement of the local ESB Networks office. This is to prevent damage to existing cables and consequent safety risk for workers.
 - Liaise with ESB Networks to confirm location of all cables. All Excavation work to be in accordance with HSA Code of Practice

25B

LV Ducting for Non Domestic Connections Duct laid to Mini Pillar Location

The new duct must only be put into the vault with an ESB Networks person present

If no vault in front of minipillar, the limit of excavation must be agreed with ESB Networks personnel locally.
Temporary and permanent reinstatement to Local Authority Standard.

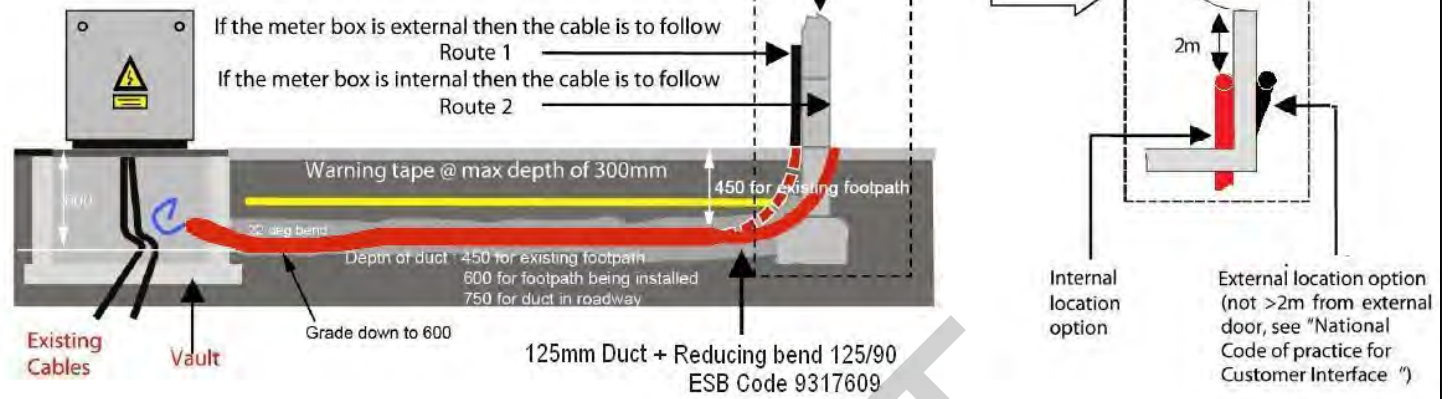

26

Specification for Standard Non-Scheme Domestic Underground Service to an Outdoor Meter Cabinet (low-voltage service not exceeding 50m) from an Overhead Network



The Customer must ensure that:

- The service pole and the complete run of the duct are both within the site boundary. ESB's Engineering Officer will confirm the service pole position and the ducting route on-site.
- An outdoor meter cabinet, to ESI Standard 12-3 (1986), is installed in a suitable location, see overleaf.
- An ESB approved "hockey stick" is installed at the meter cabinet position.
- Red ESB approved 50mm service ducting is installed at a minimum depth of 600mm between the hockey stick position and the service pole. Yellow ESB cable warning tape must be installed at a maximum depth of 300mm below ground level along the full length of the duct.
- Corrugated Ducting of any colour is not permitted.
- The duct shall be as straight as possible and free of sharp bends.
- A continuous and strong 10mm polypropylene draw rope is installed in the duct. It must be free of knots and secured at both ends of the duct.

Notes:

1. It is essential that the ESB cable does not come into contact with the cavity insulation. Allow a projection of 25mm of the hockey stick into the base of the cabinet.
2. There must be a minimum clearance of 100mm between the service duct and other services on the house-holder's property.
3. ESB will provide black UV light-resistant ducting from below the finished ground level to the top of the service pole.
4. For poles more than 50m away from the cabinet, 125mm red ESB approved ducting shall be used with an ESB approved service vault at the junction of the duct and the hockey stick.

Connection will only be made after all above requirements are met.

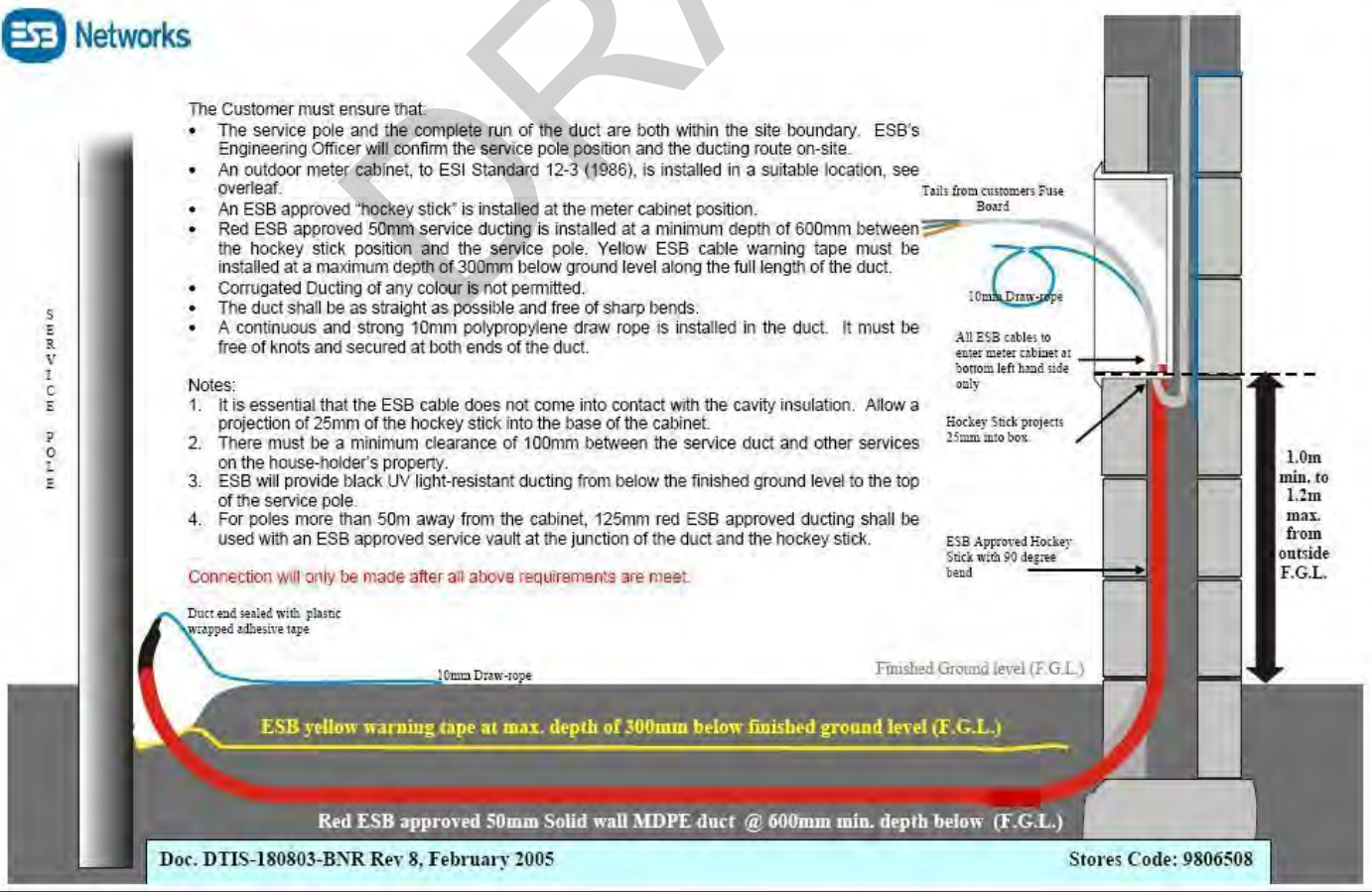

DRAFT

ANNEX A-3:

**ESBN'S STANDARD SPECIFICATIONS FOR ESB 38 KV
DUCTING/CABLING**

Standard Specification for ESB 38kV Networks Ducting/Cabling (Minimum Standards)

Note 1 : ESB Networks reserves the right not to accept ducting which does not conform to these standards and dimensions
 Note 2 : Refer to ESB Networks for Specific job Specification. These instructions do not apply to LV/MV/110kV/220kV cable
 Note 3 : All materials (ducts, marker tapes/strips, duct surrounds, mandrels and brushes) must be ESB approved materials

ESB Networks
 Rev 0: Date 08-09
 Approved:

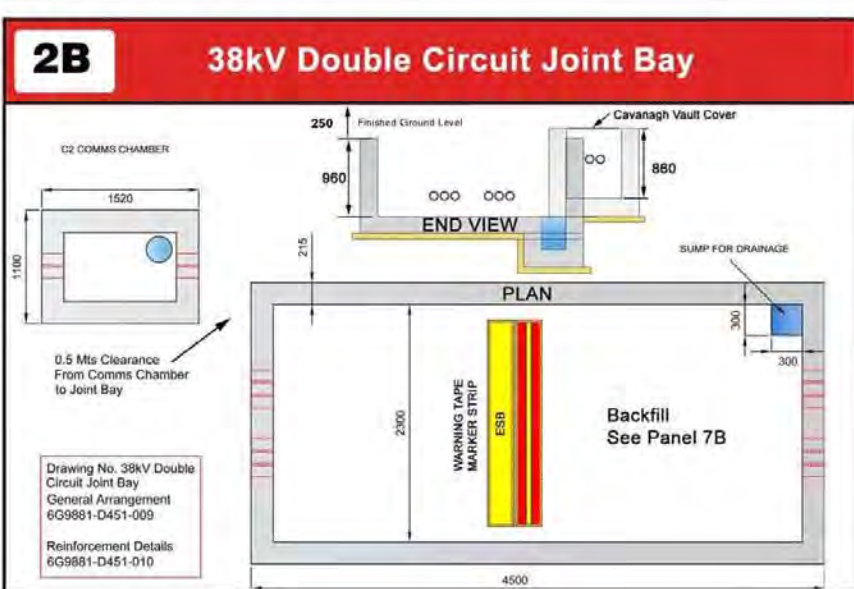
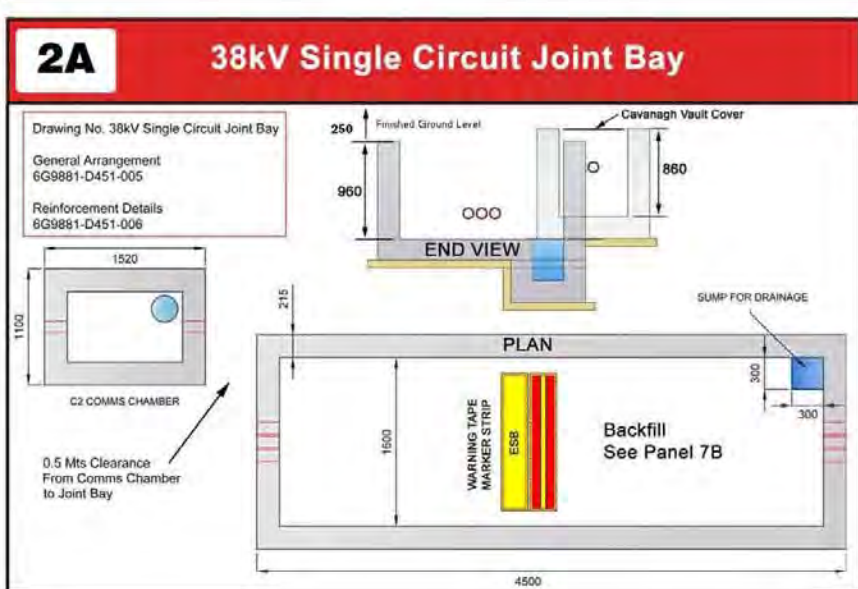
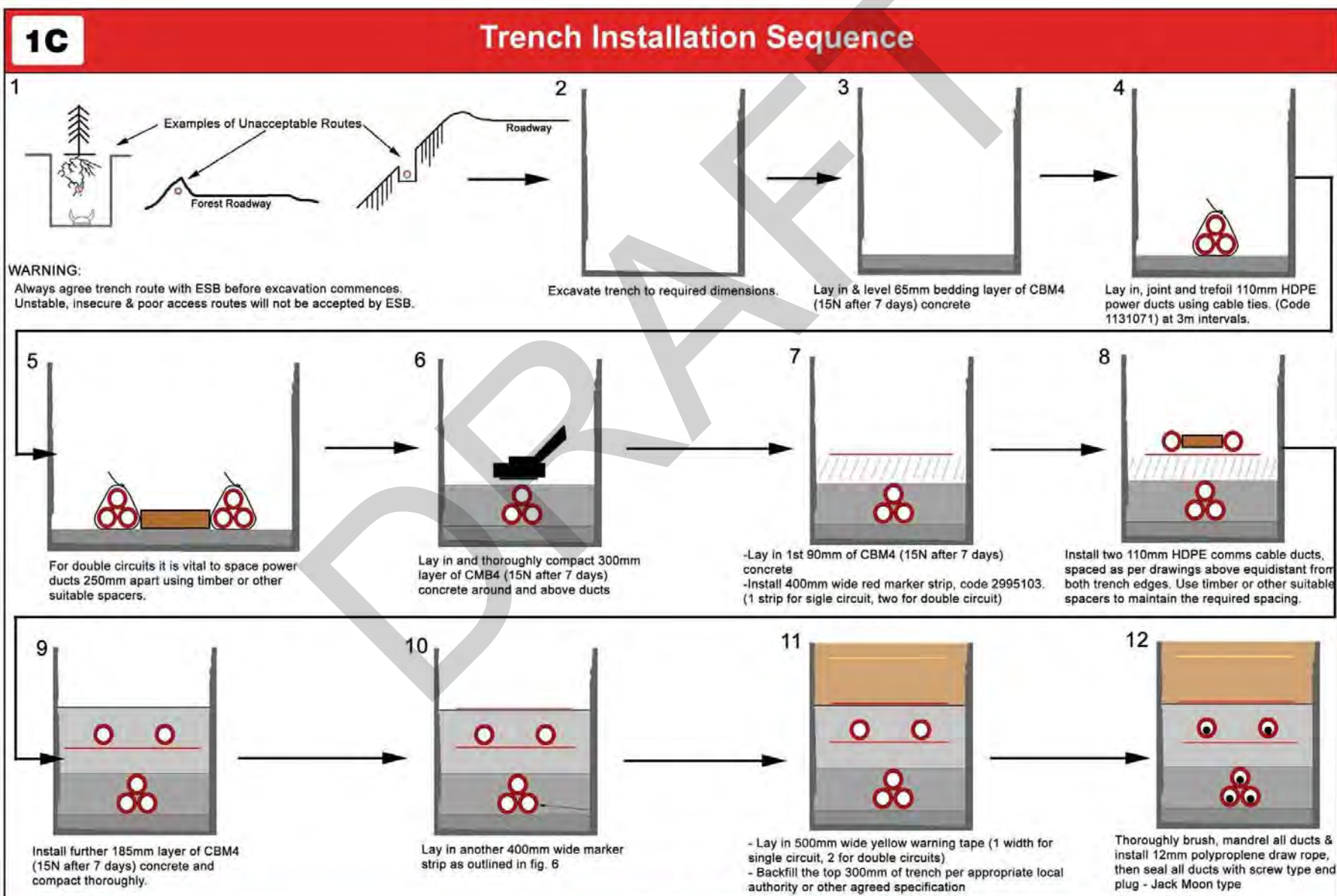
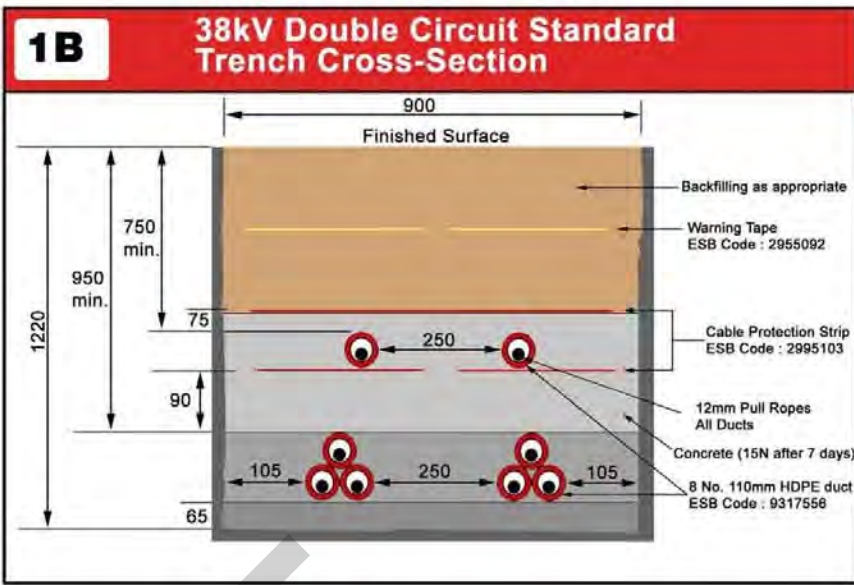
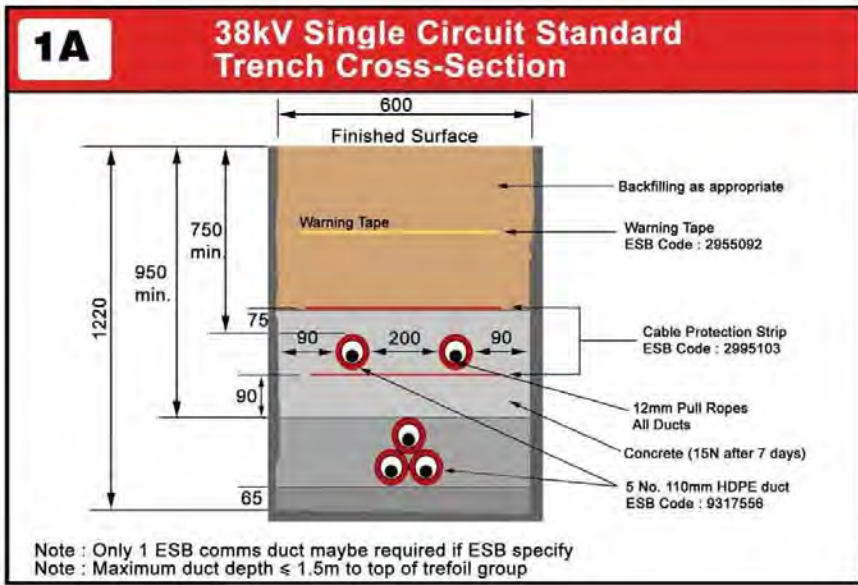

Standard Specification for ESB 38kV Networks Ducting/Cabling (Minimum Standards)

Note 1 : ESB Networks reserves the right not to accept ducting which does not conform to these standards and dimensions
 Note 2 : Refer to ESB Networks for Specific job Specification. These instructions do not apply to LV/MV/110kV/220kV cable
 Note 3 : All materials (ducts, marker tapes/strips, duct surrounds, mandrels and brushes) must be ESB approved materials



3A End Mast Termination

For existing 9m masts increase steel work height by 1.3m at mast top

12m Mast (For all new works)

Anti-Climbing Guard

Cable Assembly Drawing Number : D205778

EARTH GRID

3B Triple Pole Structure

Cable Steel Work Code: 1286697

Made up anti-climbing guard

7m Min Dimension to Bare Metal Use 12m Pole

3C Station Termination

To Cubicle

If Cable run <50m install lightning arrestors.

Assess need for mesh screen guard (Code: 3175003)

Drg. No A3205856

Clearances : Phase to:
 - Phase 500mm outdoor
 - Earth 500mm outdoor

3D Earth Grids

10m PLAN

10m

3m approx.

1.5m

1.5m

12 Rod Earth Grid For 3-Pole Structure

12 Rod Earth Grid For Mast Structure

Earth Grid resistances <10 Ohms. If ground is known to be high resistance, plan ahead and put additional earthwire into cable trench.

Drg. No. A4D 205343 PE424-D901-911-001-000

Warning Tape

500

300

4A Obligation of Duct Installer to minimise the number and severity of duct bends

The duct installer must minimise the number and severity of preformed bends in ground with obstructions and other utility service crossings by opening ground 15m ahead of backfilled duct, wherever practical to do so. This safety obligation, which may require use of steel plating, allows the duct installer to pick the least bendy duct route through utility crossings and obstructions. Otherwise, numerous sharp unrecorded duct route deviations will be present making cable installation considerably more difficult and less safe for the cable installer.

Obstructions

Backfilled Duct

Digger

Dig 15m Ahead of duct to uncover obstructions

4B Standard for Brushing, Mandrelling, Roping and End-Capping of 38kV ducts

All Ducts must be:

- Thoroughly brushed and mandrelled to prove ducts against debris /excessive deflection
- Roped using 12mm polypropylene rope with certified safe breaking load of 1.5 tons – all rope joints to be properly spliced and PVC taped over. Approved Supplier Silver Strand Bunclana Donegal, ph (074) 9382503 - 500m drum lengths available to minimise splicing/coil handling
- Sealed using endcaps against grit and water getting into them

NB: Replace mandrels once mandrel wear indicators or grooves are worn down
 Replace brushes once brush diameter falls 5mm below dimensions in table below

- Approved endcaps, both disposable and reusable types, are available from suppliers of approved ESB ducting
- Approved ESB Mandrel and brush suppliers :

Brandon Agencies, Rathnew, Co Wicklow: Phone 0404 20500 (Brushes & Mandrels)
 IS Varian, Greenhills Industrial Estate, Walkinstown, Dublin 12 Phone: 01-4501150 (Brushes Only)
 Clydesdale UK Phone 086 172 6665 (Brushes & Mandrels)
 Tynagh Network Systems, Loughrea, Co Galway. Phone: 091 842206 (Brushes & Mandrels)

110mm HDPE Duct Size

85mm	250mm	100mm	250mm
Mandrel	Brush	Brush	Sponge
Code: 9317548	Code: 8783255	Code: 8783252	

4C Approved ESB Ducting for 38kV Cables

- Use only solid wall high impact resistance ESB approved HDPE red ducting to IS 370 colour standard and ESB specification 16113 (6.3mm minimum wall thickness) Discoloured or unidentified ducting not acceptable. All duct material must be approved by ESB Networks.
- Lightweight flexible corrugated twinwall ducting is not acceptable to ESB irrespective of manufacturer
- Current approved HDPE Duct and duct bend manufacturers are: Lynplast (bend fittings only), Uponor-Radius Systems, Wavin, Quality Plastics

4D Specification for Duct Jointing for 38kV Cables

Mallet or Hammer

Timber block to protect end of duct from damage

Long Coupler

Fully jointed Duct Marks

All ducts to be securely jointed by tapping against timber board on each duct until the black depth insertion mark is reached

Always smear duct lubricant on coupler rubber ring

4E Repair of Existing Ducts

Use only approved slip couplers from approved manufacturers in section 4C

Damaged Duct Section

Slip Coupler

Slip Coupler

Repair length

- Cut out damaged section of duct and ensure all cut surfaces are square and free from sharp edges
- Slide, position and centre the repair couplers on the centering marks

4F Sealing of Ducts

All ducts to be permanently sealed at both ends of duct run
 Ducts to be temporarily sealed during installation using endcaps provided with each bale

Endcap Plain End

ESB Code 110mm: 9317569

Standard Specification for ESB 38kV Networks Ducting/Cabling (Minimum Standards)

Note 1 : ESB Networks reserves the right not to accept ducting which does not conform to these standards and dimensions
 Note 2 : Refer to ESB Networks for Specific job Specification. These instructions do not apply to LV/MV/110kV/220kV cable
 Note 3 : All materials (ducts, marker tapes/strips, duct surrounds, mandrels and brushes) must be ESB approved materials

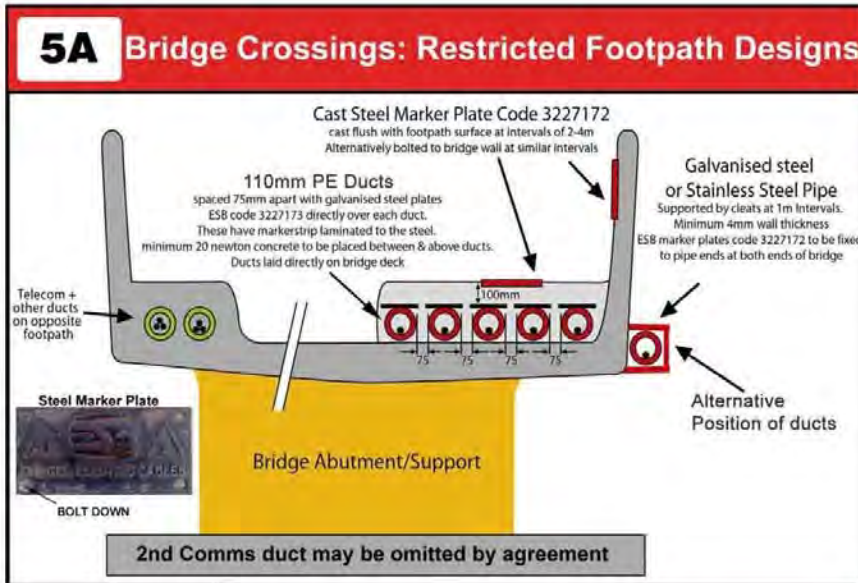

- ### 5B Bridge Crossings: Restricted Footpath Designs
1. The design must be agreed with the bridge authority. Position in footpath is preferred.
 2. Minimum cover over ducts on footpath 100mm.
 3. Where duct cover is > 300mm, marker strip & surface marker plates can be used.
 4. Red ducting is not suitable for cable run external to bridges.
 5. Where possible galvanised steel/stainless steel piping should be used, all joints must be free of weld burrs on inside. Alternatively heavy duty 10mm wall thickness black HDPE material with cast steel marker plates attached must be used to permanently warn of presence of electric cable.

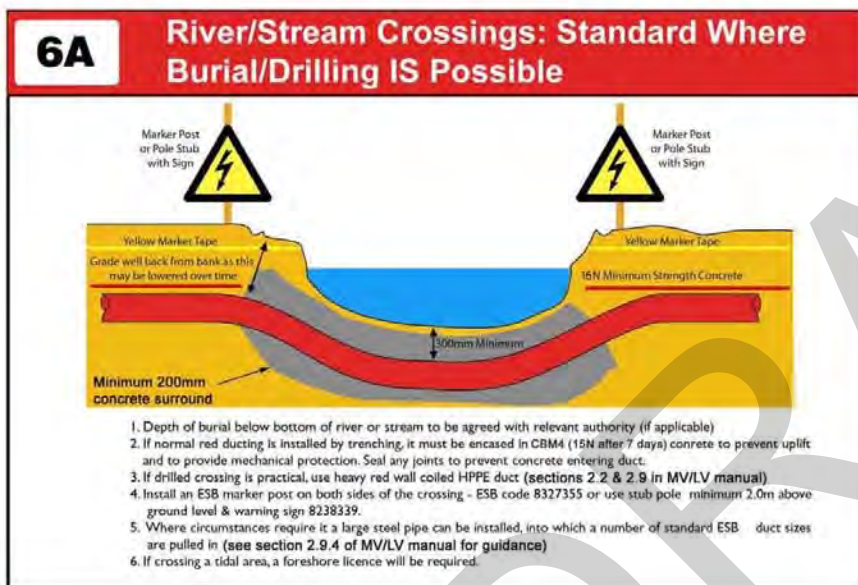

- ### 6B River/Stream Crossings: Standard Where Burial/Drilling IS NOT Possible
-
- Marker Post or Pole Stub with Sign**
- Yellow Marker Tape**
1. Installation on base of river or stream to be agreed with relevant authority (if applicable)
 2. Heavy wall steel pipe to be used free of weld beads/swarf. Minimum 8mm steel wall thickness to be used. Encase in CBM4 (15N after 7 days) concrete for corrosion protection, minimum 100mm surround
 3. Install an ESB marker post on both sides of the crossing - ESB code 8327355 or use stub pole minimum 2.0m above ground level & warning sign 8238339.
 4. Ensure a smooth connection using rubber coupler between crossing pipe size and ESB standard duct as the steel pipe size will usually differ from the standard ESB ducting. Alternatively run ESB ducting right through the steel pipe
 5. If crossing tidal area, a foreshore licence will be required.

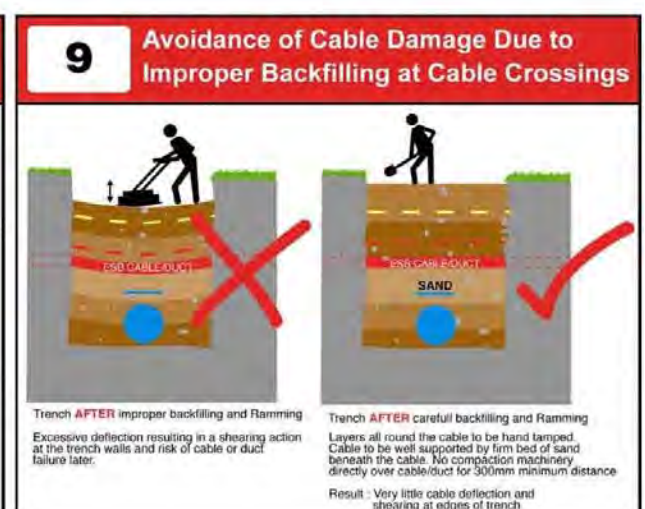
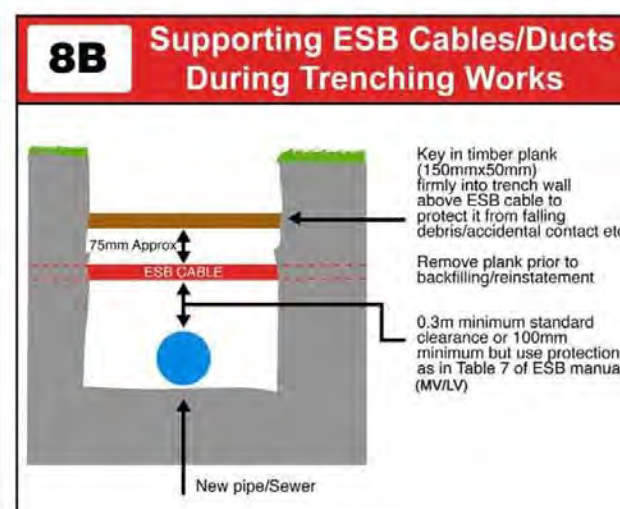
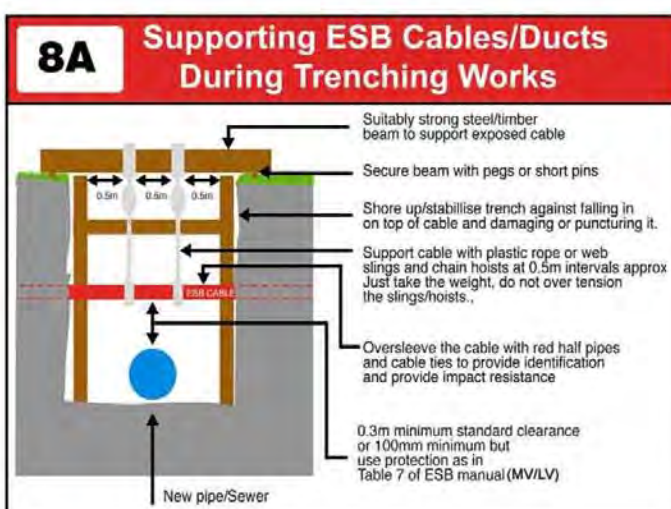
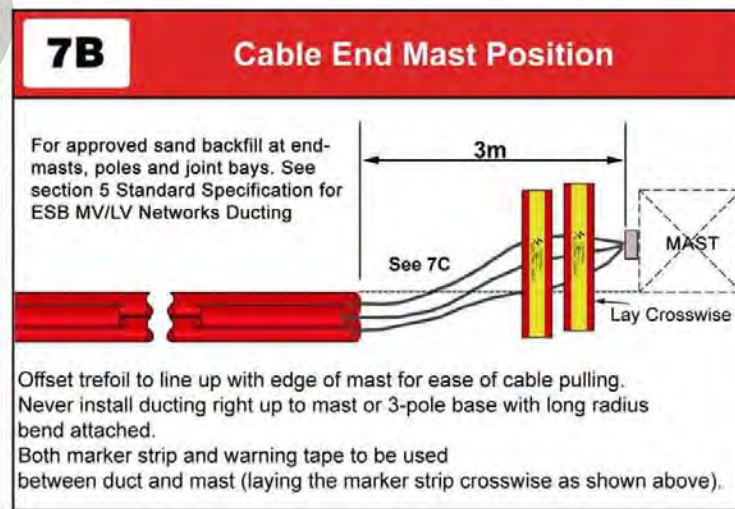
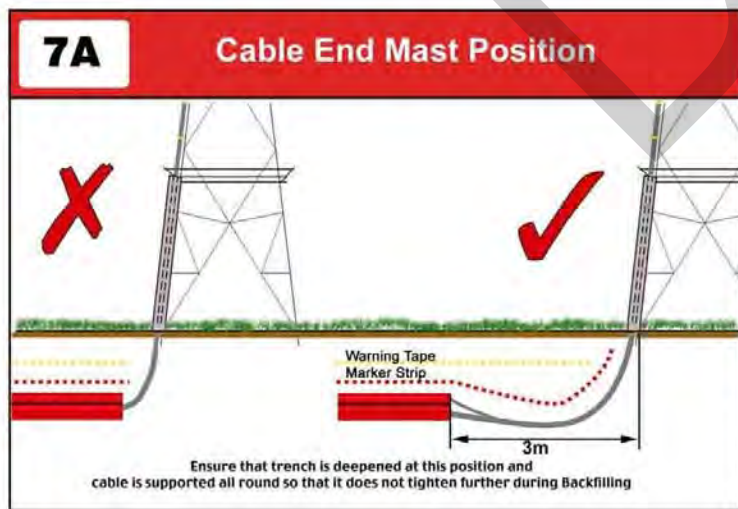

10A 38kV Railway Crossing Details

ESB Signpost

3m

Drilling pits outside CIE property line

Formal licence for crossing and approval required from CIE. Accurately record crossing location & erect marker posts.

10B Directional Drill/Thrust Bore Duct Bore Details

DESIGN 1

Minimum internal bore size = 325mm for 5 ducts

=290mm for 4 ducts where approved by ESB

5 no. 110mm diameter HDPE ducts

Alternatively use 2 x 37mm HDPE ducts for comms cables with C2 chamber on each side of the crossing to permit pulling along entire route. (See 10C)

Completed interstitial space to be bentonited thoroughly to maintain cable rating. Accurately record crossing location & erect marker posts.

10C Directional Drill/Thrust Bore Duct Bore Details

ALTERNATIVE DESIGN

ESB Signpost

ESB Signpost

37

37

Install 1 no. 200mm SDR 17.6 duct with 6 no. short length cables pulled into this pipe along with 2 x 37mm comms ducts. Full cable joint bays are required on either side of crossing along with C2 chambers for this design. This method is used where it is not practical to install large diameter pipe -eg. risk of ground upheaval or presence of obstructions. Completed interstitial space to be thoroughly bentonited to maintain cable rating. Accurately record crossing location & erect marker posts.

10D Double Circuit Bore Crossing

Standard Design

3m min

-Both Bentonited

Separate drilling for each circuit crossing

Alternative

HDPE or steel thrust bore pipe Diameter ID= 400mm

6 no. 110mm Power ducts + 2 no. 110mm comms ducts

2 no. sets of 110mm HDPE ducts - 8 ducts in total. All crossings to be accurately recorded and signposts erected given impracticality of marker tape. If both circuits = 40MVA then use 630 Cu cable

12 Minimum Standard Clearances to Other Services

Normal Services 300

Large Pressure High Pressure Pipes 600

Clearances less than the above at pinch points and crossings requires placement of additional mechanical protection (concrete slab/brick) and agreement of ESB

ESB ducts must never be laid over other services on parallel runs, except with the written prior agreement of the other utilities and ESB

Other services must never be laid directly over ESB ducts on parallel runs

13 Combined MV & 38kV Cable Runs

38kV Trench

MV/LV Cables

Yellow Marker Tape

Red Marker Strip

Pilot Cables

Concrete Surround

1.1m to 1.25m Depending on Location

150mm

150mm

Additional MV/LV Ducts as Required

300mm Strict Minimum Separation

Where it is impractical to avoid such trench runs, the separation of 300mm should be strictly controlled and monitored to minimise derating (See MV/LV manual page 180)

14 Sealing and Protection of 38kV Cables Once They Exit Ducts

Duct

Ducts to be thoroughly using ESB approved water sealant and 4hr fire rating approved for firestop. NB - All joint bay duct entries to be thoroughly sealed to prevent sand washout and subsidence.

Sandbags or other durable support for cable as it exits ducts to prevent damage to cable sheath

15 Duct Crossovers Are Not Allowed

Be especially careful when going from flat to trefoil formation in vicinity of services

16 Crossing Dumps/Contaminated Ground

Thoroughly seal all joints with adhesive water-tight duct jointing compound and pressure test for airtightness. Gasketed couplers alone are inadequate. Fusion welded couplers are also acceptable but require red over-taping.

NB. Avoid whenever possible due to: Subsidence, methane gas & severe thermal derating risks. Seek advice from ug networks section to ensure rating of cable is adequate (derating of 50% can occur) NB. Waste oils and chemicals can also seriously damage cables

Seal all duct joints with duct adhesive compound or use continuous duct lengths & seal all duct ends in joint bays. Alternatively weld pipes.

Concrete is continued up to 300mm of final surface to offset derating (CBM4 - 15N after 7 days)
